

TURNING HOLDERS

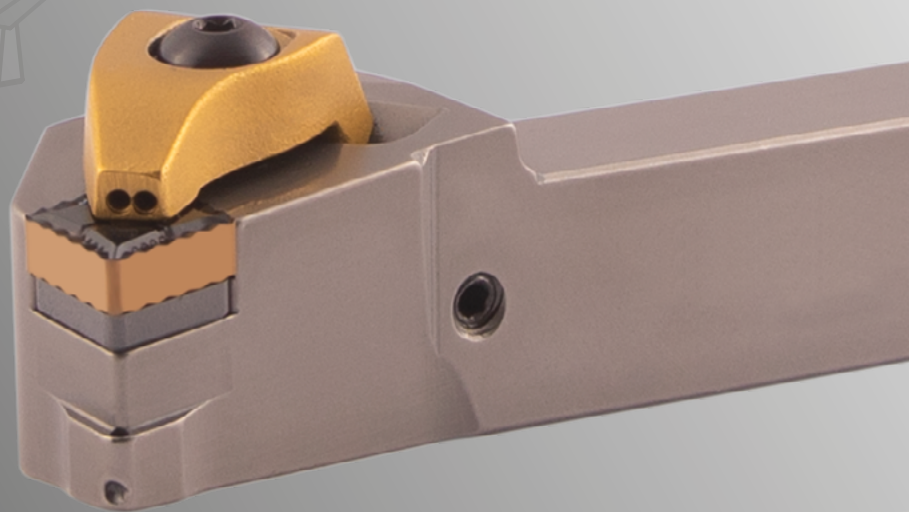

Holder Guide	P.2 - 3
EXTERNAL TURNING	P.4 - 37
T-Type Double Clamp Holders	P.4 - 14
P-Type Lever Lock Holders	P.15 - 18
M-Type Wedge Clamp Holders	P.19 - 20
C-Type Top Clamp Holders	P.21
S-Type Screw Lock Holders	P.22 - 29
Swiss Auto Type Holders	P.30 - 37
INTERNAL TURNING	P.38 - 52
P-Type Lever Lock Holders	P.38 - 42
S-Type Screw Lock Holders	P.43 - 48
Quietbore anti-vibration holders	P.49 - 52
Alpha-numeric index	P.55

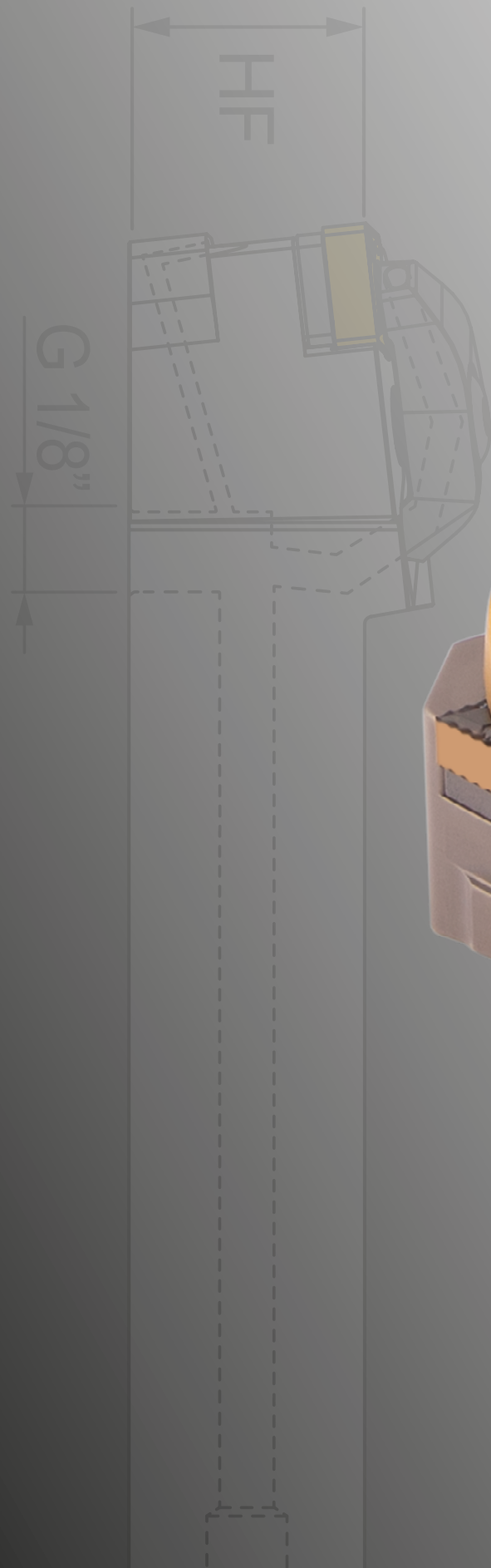



EXTERNAL TURNING HOLDER CODE

1	2	3	4	5	6	7	8	9	Optional
T	C	L	N	R	20	20	K	12	-TC
Clamping System	Insert Shape	Tool Angle	Insert Clearance	Hand	Shank Height (H)	Shank Width (B)	Length (LF)	Insert Size	Through Coolant

1. Clamping System

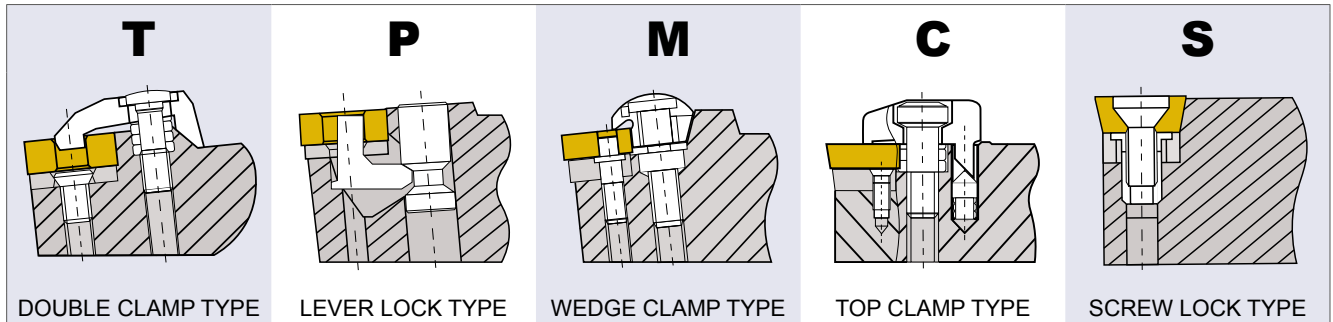

2, 4, 9. Insert Compatibility and Size



3. Tool Approach Angle

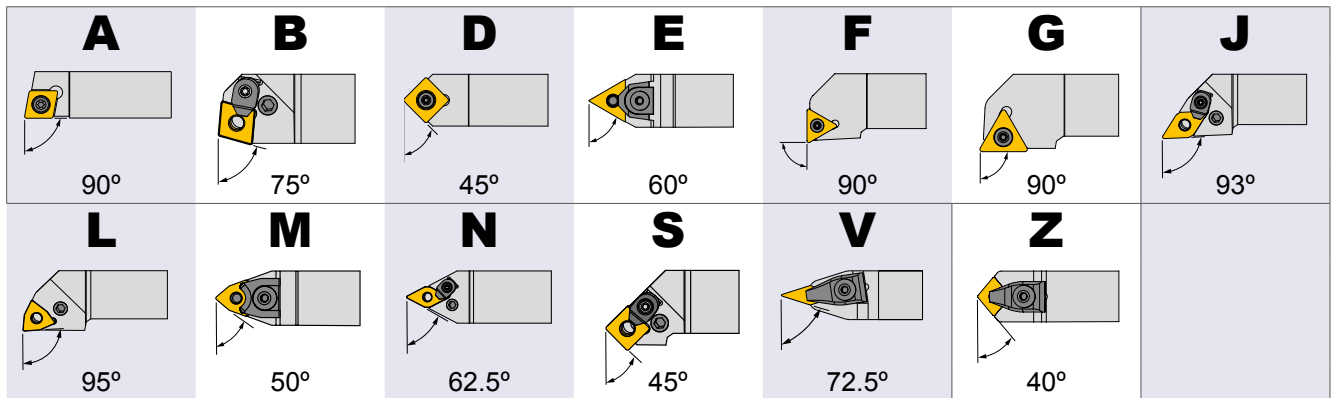

5. Tool Hand

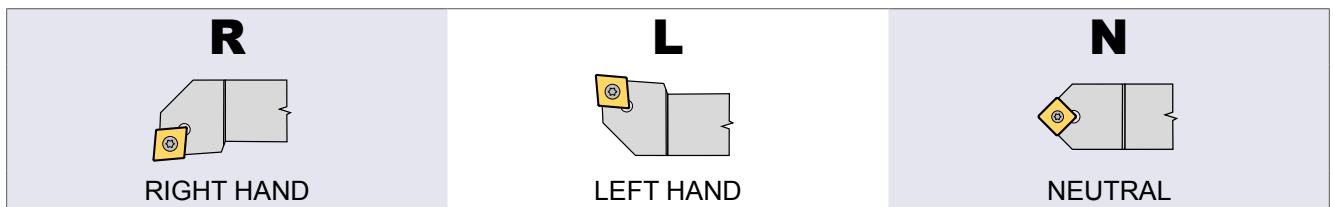

6, 7. Shank Height (H) and Width (B)

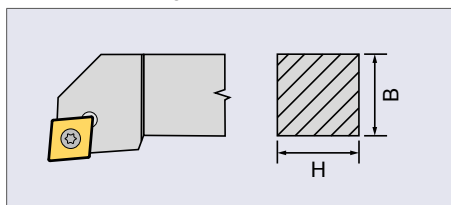

8. Overall Length (LF)

Letter	E	F	H	K	M	P
Length (mm)	70	80	100	125	150	170
Letter	Q	R	S	T	U	V
Length (mm)	180	200	250	300	350	400

INTERNAL TURNING HOLDER CODE

1	2	3	4	5	6	7	8	9
S	12	M	S	C	L	C	R	09
Coolant & Material	Shank Dia (DCON)	Length (LF)	Clamping System	Insert Shape	Tool Angle	Insert Clearance	Hand	Insert Size

1. Coolant Type and Shank Material

Letter	A	E	S
Coolant Type	Through Coolant	Through Coolant	Solid
Shank Material	Steel	Carbide	Steel

2. Shank Diameter (DCON)

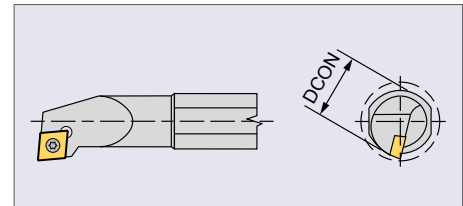

3. Overall Length (LF)

Letter	E	F	H	K	M	P
Length (mm)	70	80	100	125	150	170
Letter	Q	R	S	T	U	V
Length (mm)	180	200	250	300	350	400

4. Clamping System

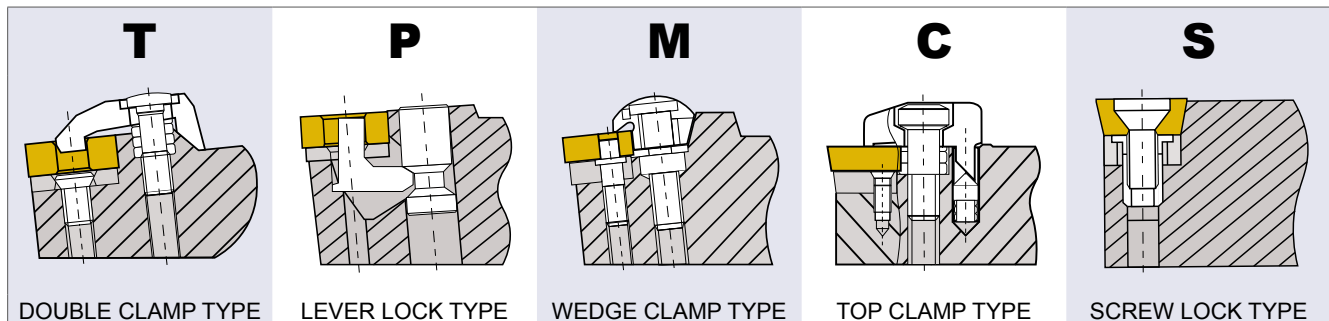

5, 7, 9. Insert Compatibility and Size

HOLDER **S12M S C L C R 09** INSERT **C C G T 09 T 302**

6. Tool Approach Angle

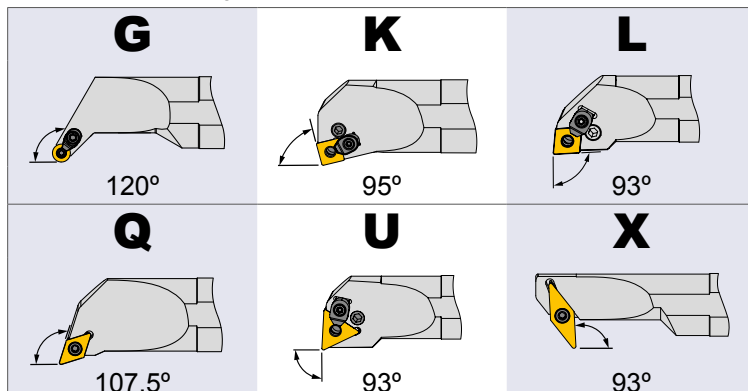

8. Tool Hand

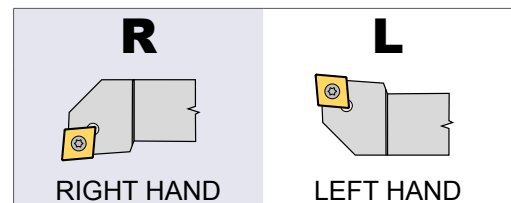



DOUBLE CLAMP EXTERNAL HOLDERS

TCBNR/L

For CN.. negative inserts

Right hand holder shown

Insert	
	CNMA 1606..
	CNMG 1606..
	CNMM 1606..

EDP Code	Description	H	HF	B	LF	WF	Clamp	Clamp Screw	Shim	Shim Screw	Spring	Washer	Key
TTH0384	TCBNR/L 2525 M16	25	25	25	150	22	TTBP-4.1	HMBV7M.1	HPC16NA	HBI6	HCY6.2	TTBR-3	HA4

To order left hand add L to EDP code. Example: TCBNL 2525 M16 = TTH0384L

TCBNR/L THROUGH COOLANT

For CN.. negative inserts

Right hand holder shown

Insert	
	CNGG 1204..
	CNMA 1204..
	CNMG 1204..
	CNMM 1204..

EDP Code	Description	H	HF	B	LF	WF	Clamp	Clamp Screw	Shim	Shim Screw	Spring	O-Ring	Key
TTH0385	TCBNR 2020 K12-TC	20	20	20	125	16	TTBC-1R	HMBV6M.2	HPC12NA	HBI5.3	HCY7	TTBR-1	HA3
TTH0385L	TCBNL 2020 K12-TC	20	20	20	125	16	TTBC-1L						
TTH0386	TCBNR 2525 M12-TC	25	25	25	150	20	TTBC-1R						
TTH0386L	TCBNL 2525 M12-TC	25	25	25	150	20	TTBC-1L						
TTH0387	TCBNR 3232 P12-TC	32	32	32	170	25	TTBC-1R						
TTH0387L	TCBNL 3232 P12-TC	32	32	32	170	25	TTBC-1L						

For coolant connection spares refer to page 54



DOUBLE CLAMP EXTERNAL HOLDERS

TCKNR/L

For CN.. negative inserts

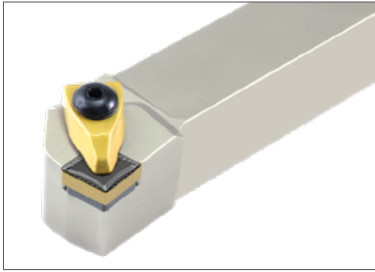

Right hand holder shown

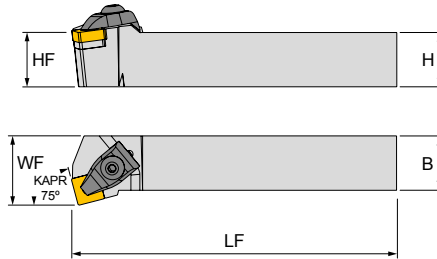
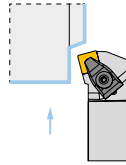

Insert	
	CNGG 1204..
	CNMA 1204.. CNMA 1606..
	CNMG 1204.. CNMG 1606..
	CNMM 1204.. CNMM 1606..

EDP Code	Description	H	HF	B	LF	WF	Clamp	Clamp Screw	Shim	Shim Screw	Spring	Washer	Key
TTH0388	TCKNR/L 2020 K12	20	20	20	125	25	TTBP-2.1	HMBV6M.1	HPC12NA	HBI5	HCY6.1	TTBR-2	HA3
TTH0389	TCKNR/L 2525 M12	25	25	25	150	32							
TTH0390	TCKNR/L 3232 P12	32	32	32	170	40							
TTH0391	TCKNR/L 2525 M16	25	25	25	150	32	TTBP-4.1	HMBV7M.1	HPC16NA	HBI6	HCY6.2	TTBR-3	HA4
TTH0392	TCKNR/L 3232 P16	32	32	32	170	40							

To order left hand add L to EDP code. Example: TCKNL 2020 K12 = TTH0388L

TCKNR/L THROUGH COOLANT

For CN.. negative inserts

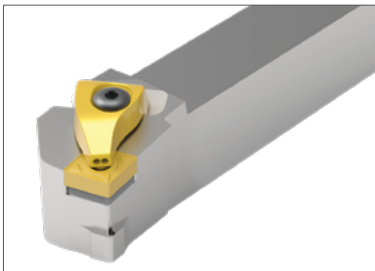

Right hand holder shown

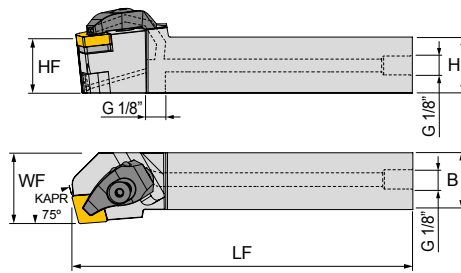
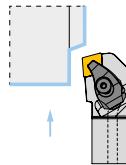

Insert	
	CNGG 1204..
	CNMA 1204..
	CNMG 1204..
	CNMM 1204..

EDP Code	Description	H	HF	B	LF	WF	Clamp	Clamp Screw	Shim	Shim Screw	Spring	O-Ring	Key
TTH0393	TCKNR 2020 K12-TC	20	20	20	125	25	TTBC-1R	HMBV6M.2	HPC12NA	HBI5.3	HCY7	TTBR-1	HA3
TTH0393L	TCKNL 2020 K12-TC	20	20	20	125	25	TTBC-1L						
TTH0394	TCKNR 2525 M12-TC	25	25	25	150	32	TTBC-1R						
TTH0394L	TCKNL 2525 M12-TC	25	25	25	150	32	TTBC-1L						
TTH0395	TCKNR 3232 P12-TC	32	32	32	170	40	TTBC-1R						
TTH0395L	TCKNL 3232 P12-TC	32	32	32	170	40	TTBC-1L						

For coolant connection spares refer to page 54

DOUBLE CLAMP EXTERNAL HOLDERS

TCLNR/L

For CN.. negative inserts

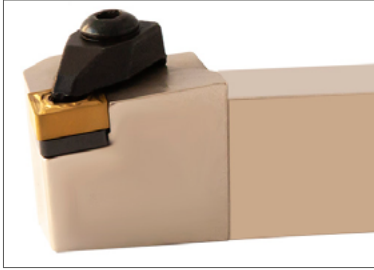

Right hand holder shown

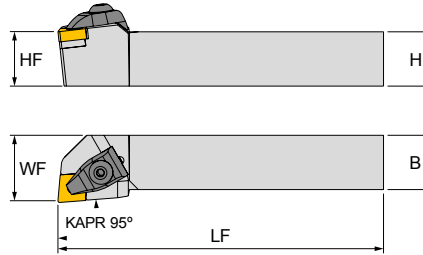
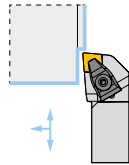

Insert	
	CNGG 1204..
	CNMA 1204.. CNMA 1606..
	CNMG 1204.. CNMG 1606..
	CNMM 1204.. CNMM 1606..

EDP Code	Description	H	HF	B	LF	WF	Clamp	Clamp Screw	Shim	Shim Screw	Spring	Washer	Key
TTH0110	TCLNR/L 2020 K12	20	20	20	125	25	TTBP-2.1	HMBV6M.1	HPC12NA	HBI5	HCY6.1	TTBR-2	HA3
TTH0111	TCLNR/L 2525 M12	25	25	25	150	32							
TTH0112	TCLNR/L 3232 P12	32	32	32	170	40							
TTH0113	TCLNR/L 4040 S12	40	40	40	250	50							
TTH0143	TCLNR/L 5050 S12	50	50	50	250	63	TTBP-4.1	HMBV7M.1	HPC16NA	HBI6	HCY6.2	TTBR-3	HA4
TTH0144	TCLNR/L 2525 M16	25	25	25	150	32							
TTH0145	TCLNR/L 3232 P16	32	32	32	170	40							

To order left hand add L to EDP code. Example: TCLNL 2020 K12 = TTH0110L

TCLNR/L THROUGH COOLANT

For CN.. negative inserts



Right hand holder shown

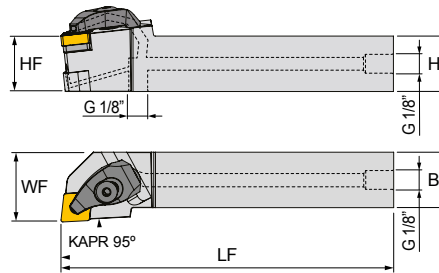
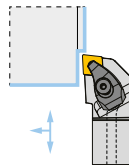

Insert	
	CNGG 1204..
	CNMA 1204..
	CNMG 1204..
	CNMM 1204..

EDP Code	Description	H	HF	B	LF	WF	Clamp	Clamp Screw	Shim	Shim Screw	Spring	O-Ring	Key
TTH0133	TCLNR 2020 K12-TC	20	20	20	125	25	TTBC-1R	HMBV6M.2	HPC12NA	HBI5.3	HCY7	TTBR-1	HA3
TTH0133L	TCLNL 2020 K12-TC	20	20	20	125	25	TTBC-1L						
TTH0134	TCLNR 2525 M12-TC	25	25	25	150	32	TTBC-1R						
TTH0134L	TCLNL 2525 M12-TC	25	25	25	150	32	TTBC-1L						
TTH0135	TCLNR 3232 P12-TC	32	32	32	170	40	TTBC-1R						
TTH0135L	TCLNL 3232 P12-TC	32	32	32	170	40	TTBC-1L						

For coolant connection spares refer to page 54



DOUBLE CLAMP EXTERNAL HOLDERS

TCMNN

For CN.. negative inserts

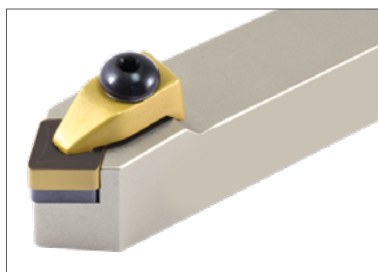

Right hand holder shown

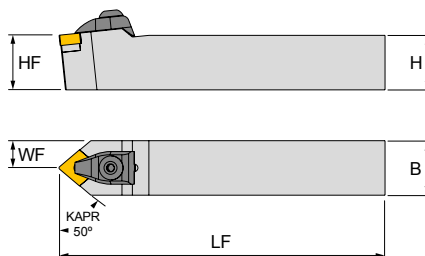
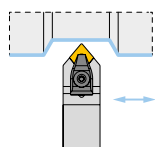

Insert	
	CNGG 1204..
	CNMA 1204.. CNMA 1606..
	CNMG 1204.. CNMG 1606..
	CNMM 1204.. CNMM 1606..

EDP Code	Description	H	HF	B	LF	WF	Clamp	Clamp Screw	Shim	Shim Screw	Spring	Washer	Key
TTH0396	TCMNN 2020 K12	20	20	20	125	10	TTBP-2.1	HMBV6M.1	HPC12NA	HB15	HCY6.1	TTBR-2	HA3
TTH0397	TCMNN 2525 M12	25	25	25	150	12.5							
TTH0398	TCMNN 3232 P12	32	32	32	170	16							
TTH0399	TCMNN 2525 M16	25	25	25	150	12.5	TTBP-4.1	HMBV7M.1	HPC16NA	HB16	HCY6.2	TTBR-3	HA4
TTH0400	TCMNN 3232 P16	32	32	32	170	16							
TTH0401	TCMNN 4040 S16	40	40	40	250	20							

TCZNN

For CN.. negative inserts



Right hand holder shown

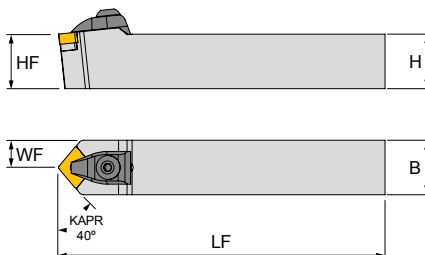
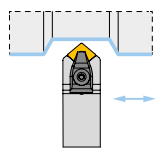

Insert	
	CNGG 1204..
	CNMA 1204.. CNMA 1606..
	CNMG 1204.. CNMG 1606..
	CNMM 1204.. CNMM 1606..

EDP Code	Description	H	HF	B	LF	WF	Clamp	Clamp Screw	Shim	Shim Screw	Spring	Washer	Key
TTH0402	TCZNN 2020 K12	20	20	20	125	10	TTBP-2.1	HMBV6M.1	HPC12NA	HB15	HCY6.1	TTBR-2	HA3
TTH0403	TCZNN 2525 M12	25	25	25	150	12.5							
TTH0404	TCZNN 3232 P12	32	32	32	170	16							
TTH0405	TCZNN 2525 M16	25	25	25	150	12.5	TTBP-4.1	HMBV7M.1	HPC16NA	HB16	HCY6.2	TTBR-3	HA4
TTH0406	TCZNN 3232 P16	32	32	32	170	16							



DOUBLE CLAMP EXTERNAL HOLDERS

TDJNR/L

For DN.. negative inserts



Right hand holder shown

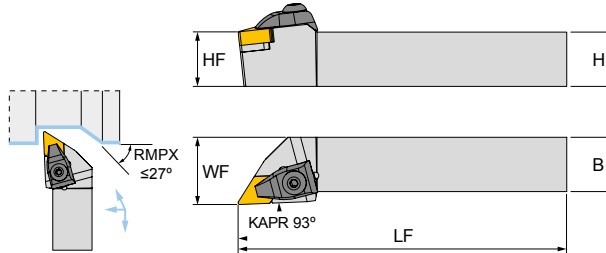

Insert	
	DNGG 1506..
	DNMA 1506..
	DNMG 1104.. DNMG 1504.. DNMG 1506..
	DNMM 1506..

EDP Code	Description	H	HF	B	LF	WF	Clamp	Clamp Screw	Shim	Shim Screw	Spring	Washer	Key
TTH0146	TDJNR/L 1616 H11	16	16	16	100	20	TTBP-1.1	HMBV5M.1	HSD11PA	HBI5.2	-	-	HA3
TTH0147	TDJNR/L 2020 K11	20	20	20	125	25							
TTH0148	TDJNR/L 2525 M11	25	25	25	150	32							
TTH0114	TDJNR/L 2020 K15	20	20	20	125	25	TTBP-2.1	HMBV6M.1	HPD15NA	HBI5	HCY6.1	TTBR-2	HA3
TTH0115	TDJNR/L 2525 M15	25	25	25	150	32							
TTH0116	TDJNR/L 3232 P15	32	32	32	170	40							
TTH0117	TDJNR/L 4040 S15	40	40	40	250	48							
TTH0149	TDJNR/L 5050 S15	50	50	50	250	63							

To order left hand add L to EDP code. Example: TDJNL 2020 K15 = TTH0114L

For DNMG 1504 inserts, order additional shim HPD15XA

TDJNR/L THROUGH COOLANT

For DN.. negative inserts

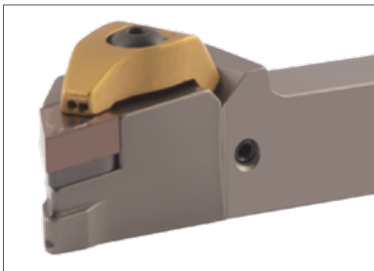

Right hand holder shown

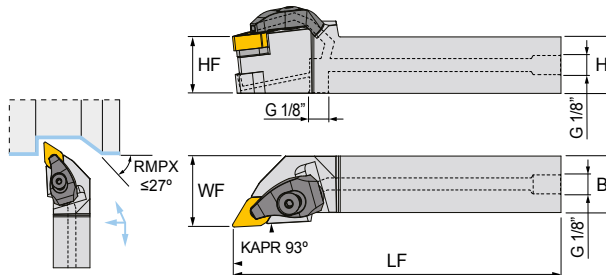

Insert	
	DNGG 1506..
	DNMA 1506..
	DNMG 1104.. DNMG 1504.. DNMG 1506..
	DNMM 1506..

EDP Code	Description	H	HF	B	LF	WF	Clamp	Clamp Screw	Shim	Shim Screw	Spring	O-Ring	Key
TTH0136	TDJNR 2020 K15-TC	20	20	20	125	25	TTBC-1R	HMBV6M.2	HDP15NA	HBI5.3	HCY7	TTBR-1	HA3
TTH0136L	TDJNL 2020 K15-TC	20	20	20	125	25	TTBC-1L						
TTH0137	TDJNR 2525 M15-TC	25	25	25	150	32	TTBC-1R						
TTH0137L	TDJNL 2525 M15-TC	25	25	25	150	32	TTBC-1L						
TTH0138	TDJNR 3232 P15-TC	32	32	32	170	40	TTBC-1R						
TTH0138L	TDJNL 3232 P15-TC	32	32	32	170	40	TTBC-1L						

For coolant connection spares refer to page 54

For DNMG 1504 inserts, order additional shim HPD15XA



DOUBLE CLAMP EXTERNAL HOLDERS

TDNNN

For DN.. negative inserts

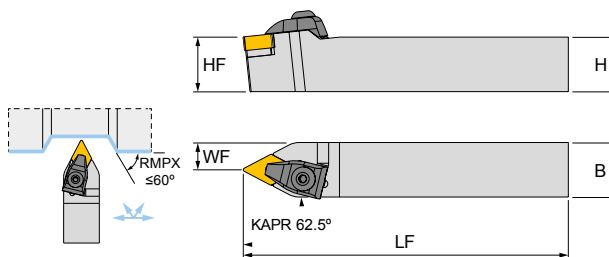

Insert	
	DNGG 1506..
	DNMA 1506..
	DNMG 1104.. DNMG 1504.. DNMG 1506..
	DNMM 1506..

EDP Code	Description	H	HF	B	LF	WF	Clamp	Clamp Screw	Shim	Shim Screw	Spring	Washer	Key
TTH0242	TDNNN 1616 H11	16	16	16	100	8	TTBP-1.1	HMBV5M.1	HSD11PA	HBI5.2	-	-	HA3
TTH0150	TDNNN 2020 K11	20	20	20	125	10							
TTH0151	TDNNN 2525 M11	25	25	25	150	12.5							
TTH0118	TDNNN 2020 K15	20	20	20	125	10	TTBP-2.1	HMBV6M.1	HPD15NA	HBI5	HCY6.1	TTBR-2	HA3
TTH0119	TDNNN 2525 M15	25	25	25	150	12.5							
TTH0243	TDNNN 3232 P15	32	32	32	170	16							
TTH0244	TDNNN 4040 S15	40	40	40	250	20							
TTH0407	TDNNN 5050 S15	50	50	50	250	25							

For DNMG 1504 inserts, order additional shim HPD15XA

TDNNN THROUGH COOLANT

For DN.. negative inserts

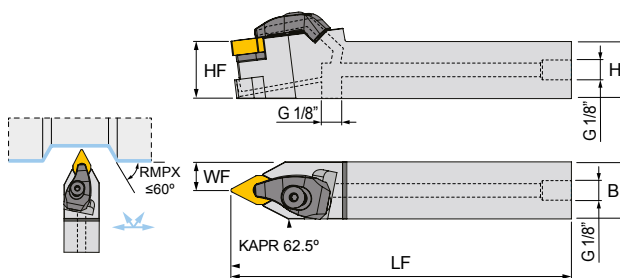
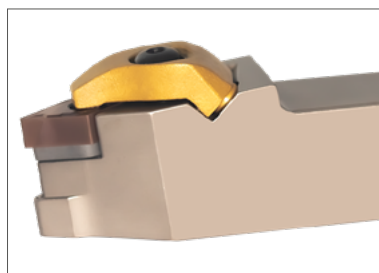

Insert	
	DNGG 1506..
	DNMA 1506..
	DNMG 1104.. DNMG 1504.. DNMG 1506..
	DNMM 1506..

EDP Code	Description	H	HF	B	LF	WF	Clamp	Clamp Screw	Shim	Shim Screw	Spring	O-Ring	Key
TTH0139	TDNNN 2525 M15-TC	25	25	25	150	12.5	TTBC-1R	HMBV6M.2	HPD15NA	HBI5.3	HCY7	TTBR-1	HA3

For coolant connection spares refer to page 54

For DNMG 1504 inserts, order additional shim HPD15XA



DOUBLE CLAMP EXTERNAL HOLDERS

TSSNR/L

For SN.. negative inserts

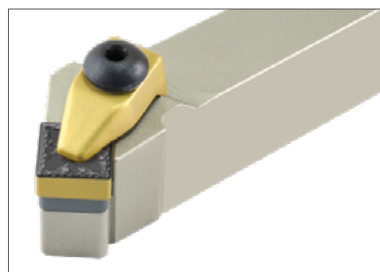

Right hand holder shown

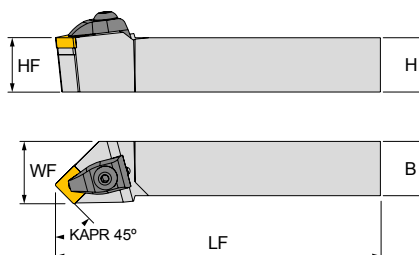
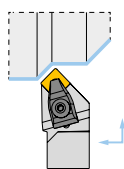

Insert	
	SNMA 1204.. SNMA 1506..
	SNMG 1204..
	SNMM 1506..

EDP Code	Description	H	HF	B	LF	WF	Clamp	Clamp Screw	Shim	Shim Screw	Spring	Washer	Key
TTH0120	TSSNR/L 2020 K12	20	20	20	125	25	TTBP-2.1	HMBV6M.1	HPS12NA	HBI5	HCY6.1	TTBR-2	HA3
TTH0121	TSSNR/L 2525 M12	25	25	25	150	32							
TTH0408	TSSNR/L 3232 P12	32	32	32	170	40							
TTH0409	TSSNR/L 2525 M15	25	25	25	150	32	TTBP-2.1	HMBV6M.1	HPS12NA	HBI5	HCY6.1	TTBR-2	HA3
TTH0410	TSSNR/L 3232 P15	32	32	32	170	40							

To order left hand add L to EDP code. Example: TSSNL 2020 K12 = TTH0120L

TSSNR/L THROUGH COOLANT

For SN.. negative inserts

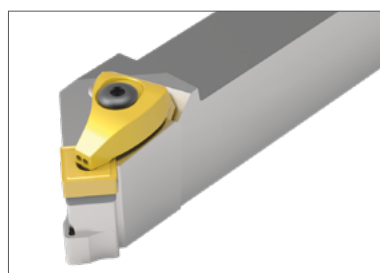

Right hand holder shown

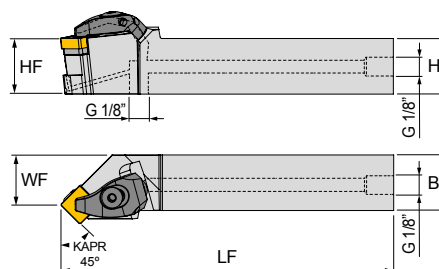
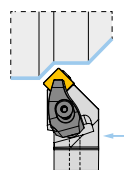

Insert	
	SNMA 1204.. SNMA 1506..
	SNMG 1204..
	SNMM 1506..

EDP Code	Description	H	HF	B	LF	WF	Clamp	Clamp Screw	Shim	Shim Screw	Spring	O-Ring	Key
TTH0411	TSSNR 2525 M12-TC	25	25	25	150	32	TTBC-1R	HMBV6M.2	HPS12NA	HBI5.3	HCY7	TTBR-1	HA3
TTH0411L	TSSNL 2525 M12-TC	25	25	25	150	32	TTBC-1L						
TTH0412	TSSNR 3232 P12-TC	32	32	32	170	40	TTBC-1R						
TTH0412L	TSSNL 3232 P12-TC	32	32	32	170	40	TTBC-1L						
TTH0413	TSSNR 2525 M15-TC	25	25	25	150	32	TTBC-2R	HMBV7M.2	HPS15NA	HBI6.1	HCY7	TTBR-1	HA4
TTH0413L	TSSNL 2525 M15-TC	25	25	25	150	32	TTBC-2L						
TTH0414	TSSNR 3232 P15-TC	32	32	32	170	40	TTBC-2R						
TTH0414L	TSSNL 3232 P15-TC	32	32	32	170	40	TTBC-2L						
TTH0415	TSSNR 4040 S15-TC	40	40	40	250	50	TTBC-2R						
TTH0415L	TSSNL 4040 S15-TC	40	40	40	250	50	TTBC-2L						

For coolant connection spares refer to page 54



DOUBLE CLAMP EXTERNAL HOLDERS

TTJNR/L

For TN.. negative inserts



Right hand holder shown

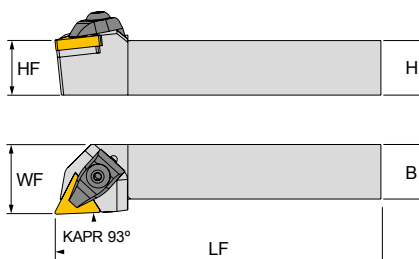
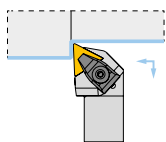

Insert	
	TNMA 1604..
	TNMG 1604.. TNMG 2204..
	TNUX 1604..

EDP Code	Description	H	HF	B	LF	WF	Clamp	Clamp Screw	Shim	Shim Screw	Spring	Washer	Key
TTH0122	TTJNR/L 2020 K16	20	20	20	125	25	TTBP-1.1	HMBV5M.1	HPT16NA	HBI5.1	-	TTBR-2	HA3
TTH0123	TTJNR/L 2525 M16	25	25	25	150	32							
TTH0416	TTJNR/L 3232 P16	32	32	32	170	40							
TTH0124	TTJNR/L 2525 M22	25	25	25	150	32	TTBP-2.1	HMBV6M.1	HPT22NA	HBI5	HCY6.1	TTBR-2	HA3
TTH0125	TTJNR/L 3232 P22	32	32	32	170	40							
TTH0126	TTJNR/L 4040 S22	40	40	40	250	50							

To order left hand add L to EDP code. Example: TTJNL 2020 K16 = TTH0122L

TTJNR/L THROUGH COOLANT

For TN.. negative inserts

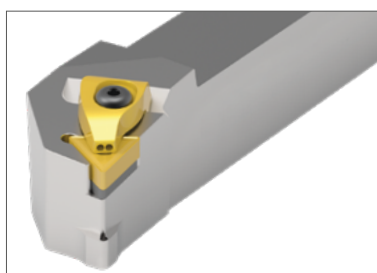

Right hand holder shown

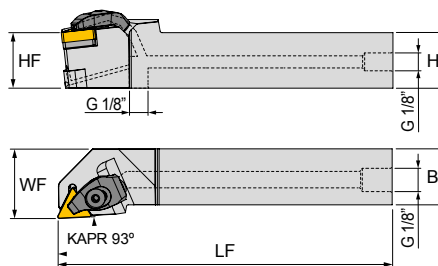
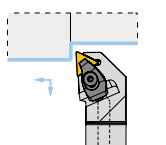

Insert	
	TNMA 1604..
	TNMG 1604.. TNMG 2204..
	TNUX 1604..

EDP Code	Description	H	HF	B	LF	WF	Clamp	Clamp Screw	Shim	Shim Screw	Spring	O-Ring	Key
TTH0417	TTJNR 2525 M16-TC	25	25	25	150	32	TTBC-3R	HMBV8M	HPT16NA	HBI5.1	HCY7.1	TTBR-1.1	HA2.5
TTH0417L	TTJNL 2525 M16-TC	25	25	25	150	32	TTBC-3L						
TTH0418	TTJNR 3232 P16-TC	32	32	32	170	40	TTBC-3R						
TTH0418L	TTJNL 3232 P16-TC	32	32	32	170	40	TTBC-3L	HMBV6M.2	HPT22NA	HBI5	HCY7	TTBR-1	HA3
TTH0419	TTJNR 2525 M22-TC	25	25	25	150	32	TTBC-1R						
TTH0419L	TTJNL 2525 M22-TC	25	25	25	150	32	TTBC-1L						
TTH0420	TTJNR 3232 P22-TC	32	32	32	170	40	TTBC-1R	HMBV6M.2	HPT22NA	HBI5	HCY7	TTBR-1	HA3
TTH0420L	TTJNL 3232 P22-TC	32	32	32	170	40	TTBC-1L						

For coolant connection spares refer to page 54



DOUBLE CLAMP EXTERNAL HOLDERS

TVJNR/L

For VN.. negative inserts

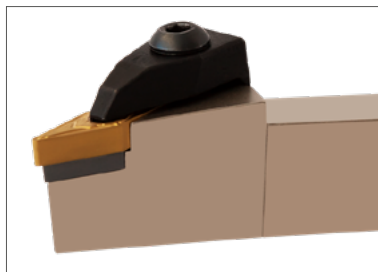

Right hand holder shown

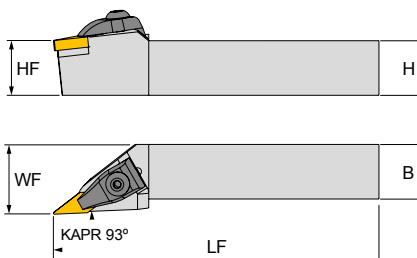
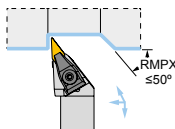

Insert	
	VNMA 1604..
	VNMG 1604..

EDP Code	Description	H	HF	B	LF	WF	Clamp	Clamp Screw	Shim	Shim Screw	Spring	Washer	Key
TTH0127	TVJNR/L 2020 K16	20	20	20	125	25	TTBP-3.1	HMBV6M.1	HPV16NA	HBI5.2	HCY6.1	TTBR-2	HA3
TTH0128	TVJNR/L 2525 M16	25	25	25	150	32							
TTH0421	TVJNR/L 3232 P16	32	32	32	170	40							

To order left hand add L to EDP code. Example: TVJNL 2020 K16 = TTH0127L

TVJNR/L THROUGH COOLANT

For VN.. negative inserts

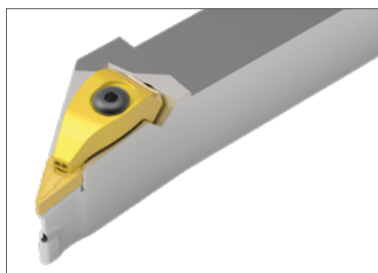

Right hand holder shown

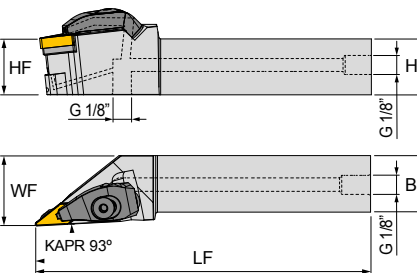
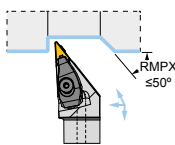

Insert	
	VNMA 1604..
	VNMG 1604..

EDP Code	Description	H	HF	B	LF	WF	Clamp	Clamp Screw	Shim	Shim Screw	Spring	O-Ring	Key
TTH0422	TVJNR 2020 K16-TC	20	20	20	125	25	TTBC-4R	HMBV6M.2	HPV16NA	HBI5.2	HCY7	TTBR-1	HA3
TTH0422L	TVJNL 2020 K16-TC	20	20	20	125	25	TTBC-4L						
TTH0423	TVJNR 2525 M16-TC	25	25	25	150	32	TTBC-4R						
TTH0423L	TVJNL 2525 M16-TC	25	25	25	150	32	TTBC-4L						
TTH0424	TVJNR 3232 P16-TC	32	32	32	170	40	TTBC-4R						
TTH0424L	TVJNL 3232 P16-TC	32	32	32	170	40	TTBC-4L						

For coolant connection spares refer to page 54



DOUBLE CLAMP EXTERNAL HOLDERS

TVVNN

For VN.. negative inserts

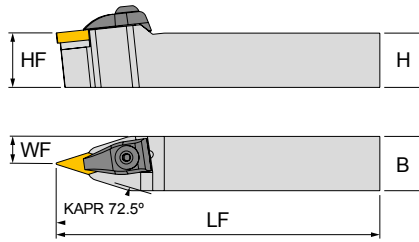
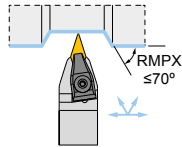

Insert	
	VNMA 1604..
	VNMG 1604..

EDP Code	Description	H	HF	B	LF	WF	Clamp	Clamp Screw	Shim	Shim Screw	Spring	Washer	Key
TTH0245	TVVNN 2020 K16	20	20	20	125	10	TTBP-3.1	HMBV6M.1	HPV16NA	HBI5.2	HCY6.1	TTBR-2	HA3
TTH0246	TVVNN 2525 M16	25	25	25	150	12.5							
TTH0247	TVVNN 3232 P16	32	32	32	170	16							

TVVNN THROUGH COOLANT

For VN.. negative inserts

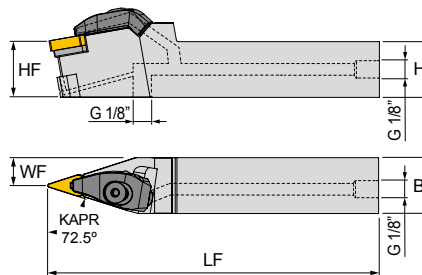
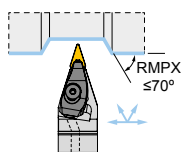
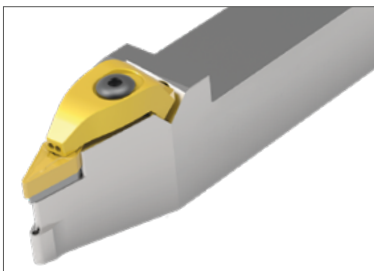

Insert	
	VNMA 1604..
	VNMG 1604..

EDP Code	Description	H	HF	B	LF	WF	Clamp	Clamp Screw	Shim	Shim Screw	Spring	O-Ring	Key
TTH0425	TVVNN 2020 K16-TC	20	20	20	125	10	TTBC-4R	HMBV6M.2	HPV16NA	HBI5.2	HCY7	TTBR-1	HA3
TTH0426	TVVNN 2525 M16-TC	25	25	25	150	12.5							

For coolant connection spares refer to page 54



DOUBLE CLAMP EXTERNAL HOLDERS

TWLNR/L For WN.. negative inserts



Right hand holder shown

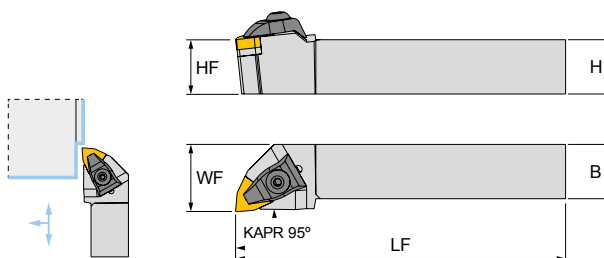

Insert	
	WNGG 0804..
	WNMA 0804..
	WNMG 0604.. WNMG 0804..

EDP Code	Description	H	HF	B	LF	WF	Clamp	Clamp Screw	Shim	Shim Screw	Spring	Washer	Key
TTH0248	TWLNR/L 1616 H06	16	16	16	100	20	TTBP-1.1	HMBV5M.1	HPW06NA	HBI4	-	-	HA3
TTH0249	TWLNR/L 2020 K06	20	20	20	125	25	TTBP-2.1	HMBV6M.1	HPW06NA	HBI5	HCY6.1	TTBR-2	HA3
TTH0250	TWLNR/L 2525 M06	25	25	25	150	32							
TTH0129	TWLNR/L 2020 K08	20	20	20	125	25	TTBP-2.1	HMBV6M.1	HPW08NA	HBI5	HCY6.1	TTBR-2	HA3
TTH0130	TWLNR/L 2525 M08	25	25	25	150	32							
TTH0131	TWLNR/L 3232 P08	32	32	32	170	40							
TTH0132	TWLNR/L 4040 R08	40	40	40	200	48							
TTH0152	TWLNR/L 5050 S08	50	50	50	250	63							

To order left hand add L to EDP code. Example: TWLNL 1616 H06 = TTH0248L

TWLNR/L THROUGH COOLANT For WN.. negative inserts

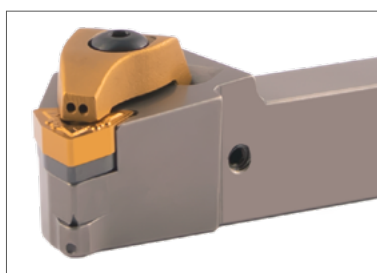

Right hand holder shown

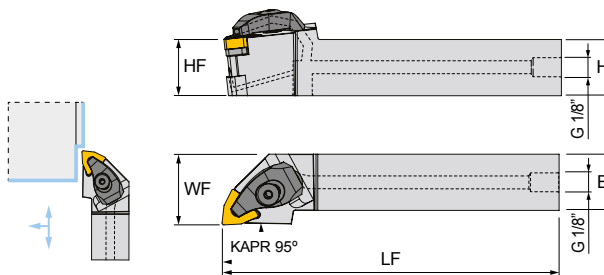

Insert	
	WNGG 0804..
	WNMA 0804..
	WNMG 0604.. WNMG 0804..

EDP Code	Description	H	HF	B	LF	WF	Clamp	Clamp Screw	Shim	Shim Screw	Spring	Washer	Key
TTH0140	TWLNR 2020 K08-TC	20	20	20	125	25	TTBC-1R	HMBV6M.2	HPW08NA	HBI5.3	HCY7	TTBR-1	HA3
TTH0140L	TWLNL 2020 K08-TC	20	20	20	125	25	TTBC-1L						
TTH0141	TWLNR 2525 M08-TC	25	25	25	150	32	TTBC-1R						
TTH0141L	TWLNL 2525 M08-TC	25	25	25	150	32	TTBC-1L						
TTH0142	TWLNR 3232 P08-TC	32	32	32	170	40	TTBC-1R						
TTH0142L	TWLNL 3232 P08-TC	32	32	32	170	40	TTBC-1L						

For coolant connection spares refer to page 54



LEVER LOCK EXTERNAL HOLDERS

PCBNR/L

For CN.. negative inserts

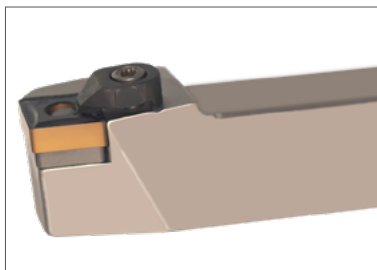

Right hand holder shown - additional security clamp

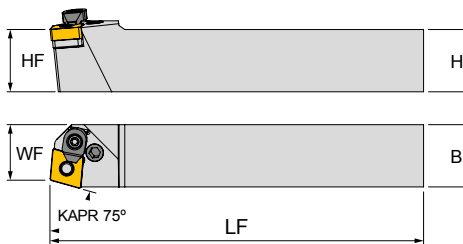

Insert	
	CNGG 1204..
	CNMA 1204.. CNMA 1606.. CNMA 1906..
	CNMG 1204.. CNMG 1606.. CNMG 1906..
	CNMM 1204.. CNMM 1606.. CNMM 1906..

EDP Code	Description	H	HF	B	LF	WF	Clamp	Clamp Screw	Shim	Shim Pin	Lever	Lever Screw	Wrench	Key
TTH0251	PCBNR/L 2020 K12C	20	20	20	125	17.5	TTAP-1	TXS4011	HPC12NA	HAY461	HL441	HLV441	TXW15	HA3
TTH0252	PCBNR/L 2525 M12C	25	25	25	150	22.5								
TTH0253	PCBNR/L 3232 P12C	32	32	32	170	29.5								
TTH0254	PCBNR/L 2525 M16C	25	25	25	150	22	TTAP-2	HBI6	HPC16NA	HAY464	HL443	HLV442	-	HA3
TTH0255	PCBNR/L 3232 P16C	32	32	32	170	27								
TTH0256	PCBNR/L 3232 P19C	32	32	32	170	27	TTAP-2	HBI6	HPC19NA	HAY465	HL444	HLV443	-	HA4
TTH0257	PCBNR/L 4040 S19C	40	40	40	250	37								

To order left hand add L to EDP code. Example: PCBNL 2020 K12C = TTH0251L

PCLNR/L

For CN.. negative inserts

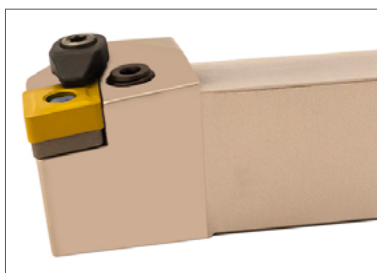

Right hand holder shown - additional security clamp

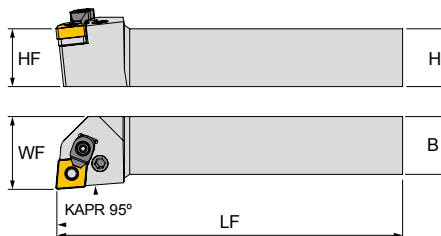

Insert	
	CNGG 1204..
	CNMA 1204.. CNMA 1606.. CNMA 1906..
	CNMG 1204.. CNMG 1606.. CNMG 1906..
	CNMM 1204.. CNMM 1606.. CNMM 1906..

EDP Code	Description	H	HF	B	LF	WF	Clamp	Clamp Screw	Shim	Shim Pin	Lever	Lever Screw	Wrench	Key
TTH0427	PCLNR/L 1616 H12	16	16	16	100	20	-	-	HPC12NA	HAY461	HL441	HLV441	TXW15	HA3
TTH0089	PCLNR/L 2020 K12C	20	20	20	125	25	TTAP-1	TXS4011						
TTH0090	PCLNR/L 2525 M12C	25	25	25	150	32								
TTH0428	PCLNR/L 3232 P12C	32	32	32	170	40	TTAP-2	HBI6	HPC16NA	HAY464	HL443	HLV442	-	HA3
TTH0153	PCLNR/L 2525 M16C	25	25	25	150	32								
TTH0154	PCLNR/L 3232 P16C	32	32	32	170	40								
TTH0155	PCLNR/L 2525 M19C	50	50	50	250	63	TTAP-2	HBI6	HPC19NA	HAY465	HL444	HLV443	-	HA4
TTH0156	PCLNR/L 3232 P19C	20	20	20	125	25								
TTH0157	PCLNR/L 4040 S19C	25	25	25	150	32								

To order left hand add L to EDP code. Example: PCLNL 2020 K12C = TTH0089L



LEVER LOCK EXTERNAL HOLDERS

PDJNR/L

For DN.. negative inserts

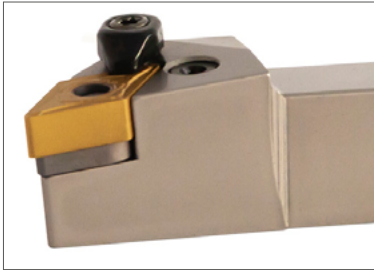

Right hand holder shown - additional security clamp

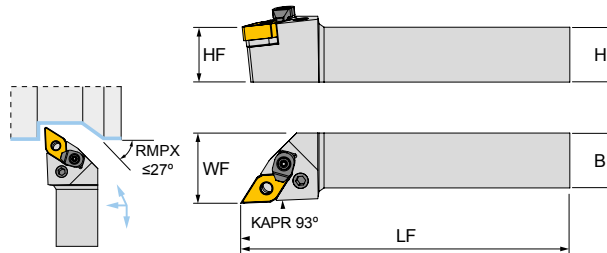

Insert	
	DNGG 1506..
	DNMA 1506..
	DNMG 1104.. DNMG 1504.. DNMG 1506..
	DNMM 1506..

EDP Code	Description	H	HF	B	LF	WF	Clamp	Clamp Screw	Shim	Shim Pin	Lever	Lever Screw	Wrench	Key
TTH0258	PDJNR/L 1616 H11	20	20	20	125	25	-	-	HPD11NA	HAY463	HL440	HLV420	-	HA2.5
TTH0259	PDJNR/L 2020 K11	25	25	25	150	32								
TTH0260	PDJNR/L 2525 M11	25	25	25	150	32								
TTH0091	PDJNR/L 2020 K15C	20	20	20	125	25	TTAP-1	TXS4011	HPD15NA	HAY461	HL442	HLV441	TXW15	HA3
TTH0092	PDJNR/L 2525 M15C	25	25	25	150	32								
TTH0261	PDJNR/L 3232 P15C	20	20	20	125	25								
TTH0262	PDJNR/L 4040 S15C	25	25	25	150	32								

To order left hand add L to EDP code. Example: PDJNL 2020 K15C = TTH0091L

For DNMG 1504 inserts, order additional shim HPD15XA

PDNNN

For DN.. negative inserts

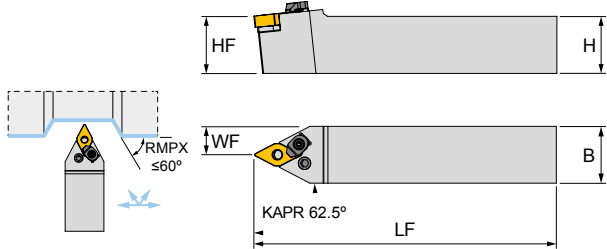
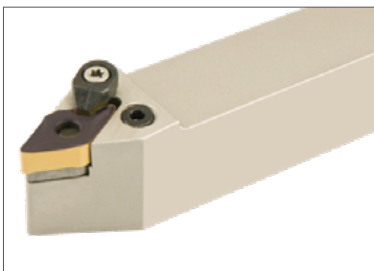

Insert	
	DNGG 1506..
	DNMA 1506..
	DNMG 1104.. DNMG 1504.. DNMG 1506..
	DNMM 1506..

EDP Code	Description	H	HF	B	LF	WF	Clamp	Clamp Screw	Shim	Shim Pin	Lever	Lever Screw	Wrench	Key
TTH0429	PDNNN 1616 H11	20	20	20	125	8	-	-	HPD11NA	HAY463	HL440	HLV420	-	HA2.5
TTH0430	PDNNN 2020 K11	25	25	25	150	10								
TTH0431	PDNNN 2525 M11	25	25	25	150	12.5								
TTH0432	PDNNN 2020 K15C	20	20	20	125	10	TTAP-1	TXS4011	HPD15NA	HAY461	HL442	HLV441	TXW15	HA3
TTH0433	PDNNN 2525 M15C	25	25	25	150	12.5								
TTH0434	PDNNN 3232 P15C	20	20	20	125	16								

For DNMG 1504 inserts, order additional shim HPD15XA



LEVER LOCK EXTERNAL HOLDERS

PSSNR/L

For SN.. negative inserts

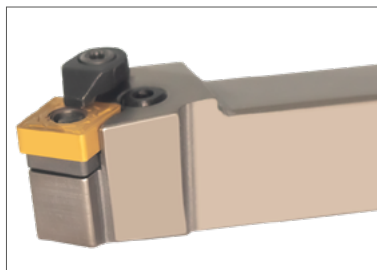

Right hand holder shown - additional security clamp

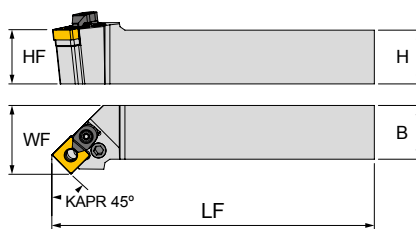
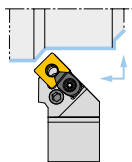

Insert	
	SNMA 1204.. SNMA 1506.. SNMA 1906..
	SNMG 0903.. SNMG 1204.. SNMG 1906..
	SNMM 1506.. SNMM 1906..

EDP Code	Description	H	HF	B	LF	WF	Clamp	Clamp Screw	Shim	Shim Pin	Lever	Lever Screw	Wrench	Key
TTH0383	PSSNR/L 1616 H09	32	32	32	170	40	-	-	HPS09NA	HAY463	HL440	HLV420	-	HA2.5
TTH0383	PSSNR/L 2020 K09	32	32	32	170	40	-	-	HPS09NA	HAY463	HL440	HLV420	-	HA2.5
TTH0263	PSSNR/L 2020 K12C	20	20	20	125	25	TTAP-1	TXS4011	HPS12NA	HAY461	HL441	HLV441	TXW15	HA3
TTH0264	PSSNR/L 2525 M12C	25	25	25	150	32								
TTH0265	PSSNR/L 3232 P12C	32	32	32	170	40								
TTH0383	PSSNR/L 3232 P15C	32	32	32	170	40	TTAP-2	HBI6	HPS15NA	HAY464	HL443	HLV442	-	HA4
TTH0266	PSSNR/L 3232 P19C	32	32	32	170	40	TTAP-2	HBI6	HPS19NA	HAY465	HL444	HLV443	-	HA4
TTH0267	PSSNR/L 4040 S19C	40	40	40	150	50								

To order left hand add L to EDP code. Example: PSSNL 2020 K12C = TTH0263L

PTJNR/L

For TN.. negative inserts

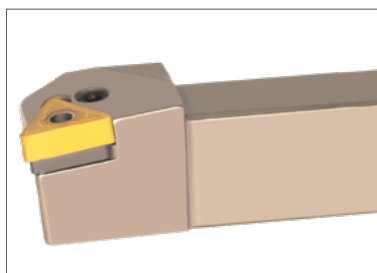

Right hand holder shown

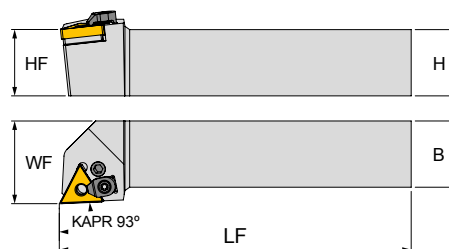
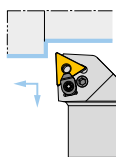

Insert	
	TNMA 1604..
	TNMG 1604.. TNMG 2204..
	TNUX 1604..

EDP Code	Description	H	HF	B	LF	WF	Clamp	Clamp Screw	Shim	Shim Pin	Lever	Lever Screw	Wrench	Key
TTH0435	PTJNR/L 1616 H16	16	16	16	100	20	-	-	HPT16NAP	HAY463	HL440	HLV420	-	HA2.5
TTH0268	PTJNR/L 2020 K16	20	20	20	125	25								
TTH0269	PTJNR/L 2525 M16	25	25	25	150	32								
TTH0270	PTJNR/L 3232 P16	32	32	32	170	40								
TTH0271	PTJNR/L 2525 M22C	25	25	25	150	32	TTAP-1	TXS4011	HPT22NA	HAY461	HL441	HLV441	TXW15	HA3
TTH0272	PTJNR/L 3232 P22C	32	32	32	170	40								

To order left hand add L to EDP code. Example: PTJNL 1616 H16 = TTH0435L



LEVER LOCK EXTERNAL HOLDERS

PWLNR/L For WN.. negative inserts

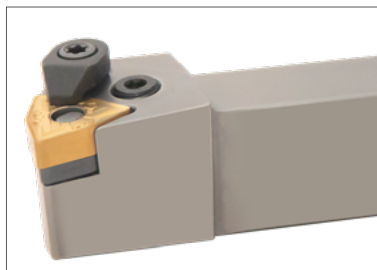

Right hand holder shown - additional security clamp

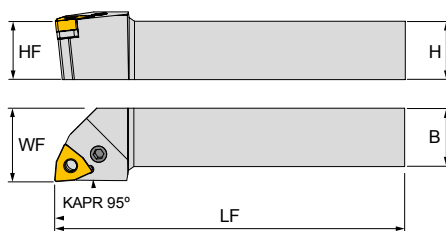
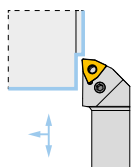

Insert	
	WNGG 0804..
	WNMA 0804..
	WNMG 0604.. WNMG 0804..

EDP Code	Description	H	HF	B	LF	WF	Clamp	Clamp Screw	Shim	Shim Pin	Lever	Lever Screw	Wrench	Key
TTH0056	PWLNR/L 1616 H06	16	16	16	100	20	-	-	HPW06NA	HAY463	HL440	HLV420	-	HA2.5
TTH0057	PWLNR/L 2020 K06	20	20	20	125	25								
TTH0273	PWLNR/L 2525 M06	25	25	25	150	32								
TTH0436	PWLNR/L 1616 H08	16	16	16	100	20	TTAP-1	TXS4011	HPW08NA	HAY461	HL441	HLV441	-	HA3
TTH0274	PWLNR/L 2020 K08C	20	20	20	125	25								
TTH0275	PWLNR/L 2525 M08C	25	25	25	150	32								
TTH0276	PWLNR/L 3232 P08C	32	32	32	170	40								

To order left hand add L to EDP code. Example: PWLNL 1616 H06 = TTH0056L



PIN & CLAMP EXTERNAL HOLDERS

MTENN

For TN.. negative inserts



Right hand holder shown

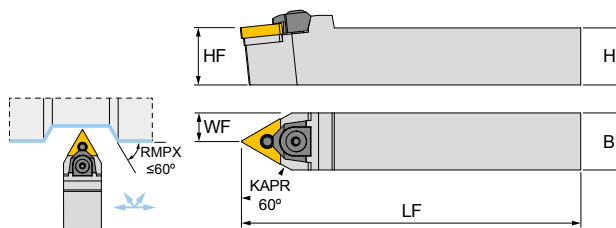

Insert	
	TNMA 1604..
	TNMG 1604.. TNMG 2204..
	TNUX 1604..

EDP Code	Description	H	HF	B	LF	WF	Clamp	Clamp Screw	Shim	Shim Pin	Spring	Washer	Key
TTH0553	MTENN 2020 K16	20	20	20	125	10	TTMC-2	HMBV6M.1	HPT16NA	HMY461	HCY6.1	TTBR-2	HA3
TTH0554	MTENN 2525 M16	25	25	25	150	12.5							
TTH0555	MTENN 3232 M16	32	32	32	170	16							
TTH0556	MTENN 2525 M22	25	25	25	150	12.5	TTMC-3	HMBV6M.1	HPT22NA	HMY462	HCY6.1	TTBR-2	HA3
TTH0557	MTENN 3232 P22	32	32	32	170	16							
TTH0558	MTENN 4040 S22	40	40	40	250	20							

MTJNR/L

For TN.. negative inserts

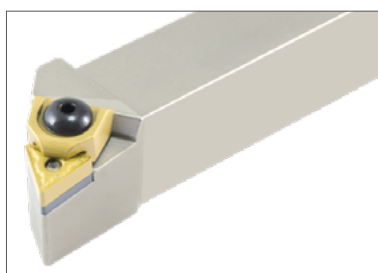

Right hand holder shown

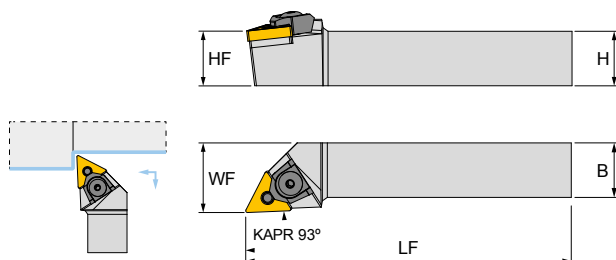

Insert	
	TNMA 1604..
	TNMG 1604.. TNMG 2204..
	TNUX 1604..

EDP Code	Description	H	HF	B	LF	WF	Clamp	Clamp Screw	Shim	Shim Pin	Spring	Washer	Key
TTH0547	MTJNR/L 2020 K16	20	20	20	125	25	TTMC-2	HMBV6M.1	HPT16NA	HMY461	HCY6.1	TTBR-2	HA3
TTH0548	MTJNR/L 2525 M16	25	25	25	150	32							
TTH0549	MTJNR/L 3232 P16	32	32	32	170	40							
TTH0550	MTJNR/L 2525 M22	25	25	25	150	32	TTMC-3	HMBV6M.1	HPT22NA	HMY462	HCY6.1	TTBR-2	HA3
TTH0551	MTJNR/L 3232 P22	32	32	32	170	40							
TTH0552	MTJNR/L 4040 S22	40	40	40	250	50							

To order left hand add L to EDP code. Example: MTJNL 2020 K16 = TTH0547L



PIN & CLAMP EXTERNAL HOLDERS

MWLNR/L

For WN.. negative inserts

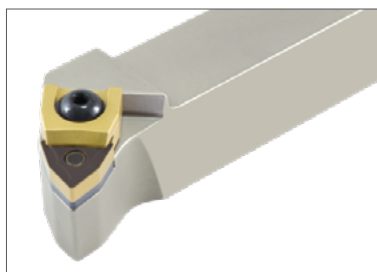

Right hand holder shown

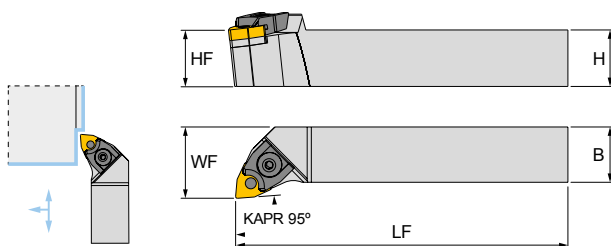

Insert	
	WNGG 0804..
	WNMA 0804..
	WNMG 0604.. WNMG 0804..

EDP Code	Description	H	HF	B	LF	WF	Clamp	Clamp Screw	Shim	Shim Pin	Spring	Washer	Key
TTH0559	MWLNR/L 1616 H06	16	16	16	100	20	TTMC-1	HMBV5M.2	-	HMY463	-	-	HA3
TTH0560	MWLNR/L 2020 K06	20	20	20	125	25							
TTH0561	MWLNR/L 2525 M06	25	25	25	150	32							
TTH0562	MWLNR/L 2020 K08	20	20	20	125	25	TTMC-3	HMBV6M.4	HPW08NA	HMY462	HCY6.1	TTBR-2	HA3
TTH0563	MWLNR/L 2525 M08	25	25	25	150	32							
TTH0564	MWLNR/L 3232 P08	32	32	32	170	40							

To order left hand add L to EDP code. Example: MWLNL 1616 H06 = TTH0559L

MWMNN

For WN.. negative inserts

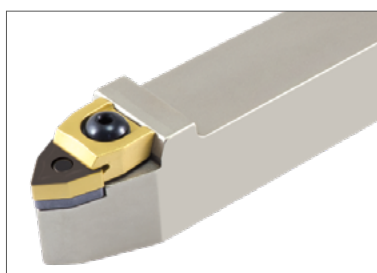

Right hand holder shown

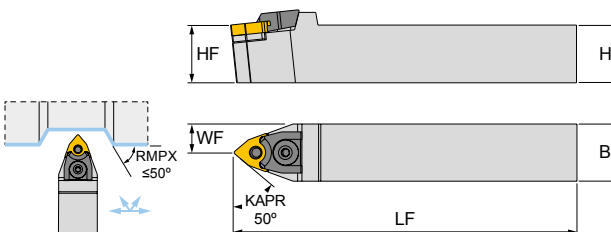

Insert	
	WNGG 0804..
	WNMA 0804..
	WNMG 0604.. WNMG 0804..

EDP Code	Description	H	HF	B	LF	WF	Clamp	Clamp Screw	Shim	Shim Pin	Spring	Washer	Key
TTH0565	MWMNN 1616 H06	16	16	16	100	8	TTMC-1	HMBV5M.2	-	HMY463	-	-	HA3
TTH0566	MWMNN 2020 K06	20	20	20	125	10							
TTH0567	MWMNN 2525 M06	25	25	25	150	12.5							
TTH0568	MWMNN 2020 K08	20	20	20	125	10	TTMC-3	HMBV6M.4	HPW08NA	HMY462	HCY6.1	TTBR-2	HA3
TTH0569	MWMNN 2525 M08	25	25	25	150	12.5							
TTH0570	MWMNN 3232 P08	32	32	32	170	16							



TOP CLAMP EXTERNAL HOLDERS

CKJNR/L

For KN.. negative inserts

Insert	
	KNUX 1604....



Right hand holder shown

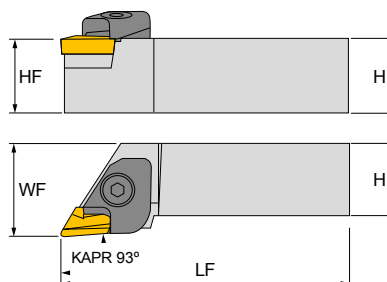
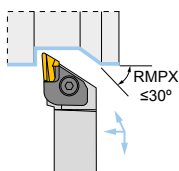

EDP Code	Description	H	HF	B	LF	WF	Clamp	Clamp Screw	Shim	Shim Screw	Spring	Washer	Key
TTH0571	CKJNR/L 2020 K16	20	20	20	125	27.5	TTCC-1R TTCC-1L	HMBV6M.3	HPK16NR HPK16NL	HBI4	HCY7.1	TTBR-2	HA4
TTH0572	CKJNR/L 2525 M16	25	25	25	150	31.5							
TTH0573	CKJNR/L 3232 P16	32	32	32	170	40							
TTH0574	CKJNR/L 4040 S16	40	40	40	250	50							

To order left hand add L to EDP code. Example: CKJNL 2020 K12 = TTH0571L



SCREW LOCK EXTERNAL HOLDERS

SCLCR/L

For CC.. positive inserts



Right hand holder shown

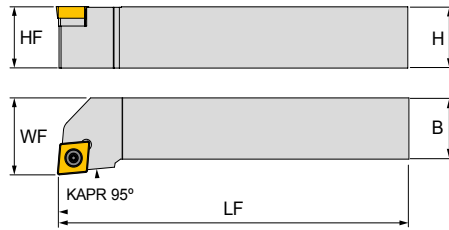
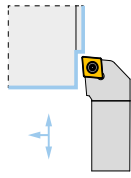

Insert	
	CCGT 0602.. CCGT 09T3.. CCGT 1204..
	CCMT 0602.. CCMT 09T3.. CCMT 1204..

EDP Code	Description	H	HF	B	LF	WF	Shim	Shim Screw	Shim Key	Insert Screw	Wrench
TTH0001	SCLCR/L 0808 E06	8	8	8	70	10	-	-	-	TXS2506	TXW08
TTH0002	SCLCR/L 1010 E06	10	10	10	70	12					
TTH0277	SCLCR/L 1212 F06	12	12	12	80	16					
TTH0278	SCLCR/L 1010 E09	10	10	10	70	12	-	-	-	TXS3509	TXW15
TTH0003	SCLCR/L 1212 F09	12	12	12	80	16				TXS3511	TXW15
TTH0004	SCLCR/L 1616 H09	16	16	16	100	20	HSC09PA	HSAV35	HA3.5	TXS3514	TXW15
TTH0005	SCLCR/L 2020 K09	20	20	20	125	25					
TTH0006	SCLCR/L 2525 M09	25	25	25	150	32					
TTH0279	SCLCR/L 1616 H12	16	16	16	100	20	-	-	-	TXS5011	TXW20F
TTH0007	SCLCR/L 2020 K12	20	20	20	125	25	HSC12PA	HSAV45	HA4.5	TXS4516	TXW20F
TTH0008	SCLCR/L 2525 M12	25	25	25	150	32					

To order left hand add L to EDP code. Example: SCLCL 0808 E06 = TTH0001L



SCREW LOCK EXTERNAL HOLDERS

SDJCR/L

For DC.. positive inserts



Right hand holder shown

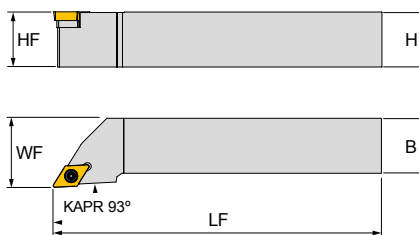
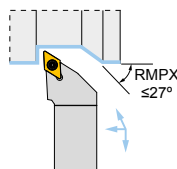

Insert	
	DCGT 0702.. DCGT 11T3..
	DCMT 0702.. DCMT 11T3..

EDP Code	Description	H	HF	B	LF	WF	Shim	Shim Screw	Shim Key	Insert Screw	Wrench
TTH0280	SDJCR/L 0808 E07	8	8	8	70	10	-	-	-	TXS2506	TXW08
TTH0068	SDJCR/L 1010 E07	10	10	10	70	12					
TTH0069	SDJCR/L 1212 F07	12	12	12	80	16					
TTH0281	SDJCR/L 1616 H07	16	16	16	100	20					
TTH0070	SDJCR/L 1212 F11	12	12	12	80	16	HSD11PA	HSAV35	HA3.5	TXS3514	TXW15
TTH0071	SDJCR/L 1616 H11	16	16	16	100	20					
TTH0072	SDJCR/L 2020 K11	20	20	20	125	25					
TTH0073	SDJCR/L 2525 M11	25	25	25	150	32					
TTH0282	SDJCR/L 3232 P11	32	32	32	170	40					

To order left hand add L to EDP code. Example: SDJCL 0808 E07 = TTH0280L

SDNCN

For DC.. positive inserts

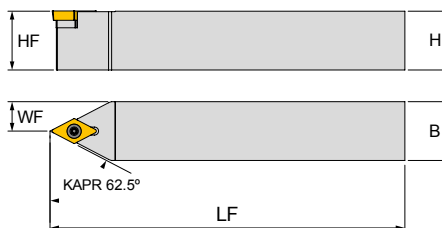
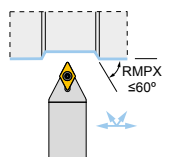

Insert	
	DCGT 0702.. DCGT 11T3..
	DCMT 0702.. DCMT 11T3..

EDP Code	Description	H	HF	B	LF	WF	Shim	Shim Screw	Shim Key	Insert Screw	Wrench
TTH0283	SDNCN 0808 E07	8	8	8	70	4	-	-	-	TXS2506	TXW08
TTH0109	SDNCN 1010 E07	10	10	10	70	5					
TTH0285	SDNCN 1212 F07	12	12	12	80	6					
TTH0286	SDNCN 1616 H07	16	16	16	100	8					
TTH0287	SDNCN 1616 H11	16	16	16	100	8	HSD11PA	HSAV35	HA3.5	TXS3514	TXW15
TTH0288	SDNCN 2020 K11	20	20	20	125	10					
TTH0289	SDNCN 2525 M11	25	25	25	150	12.5					
TTH0290	SDNCN 3232 P11	32	32	32	170	16					



SCREW LOCK EXTERNAL HOLDERS

SRGCR/L

For RC.. positive inserts



Right hand holder shown

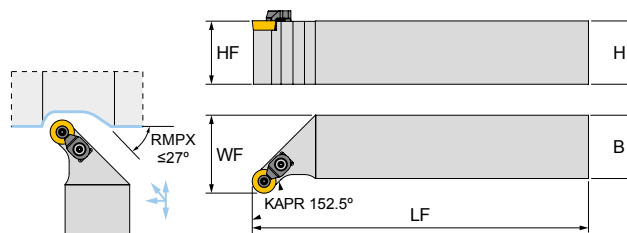

Insert	
	RCMT 0602..
	RCMT 0803..
	RCMT 10T3..
	RCMT 1204..

EDP Code	Description	H	HF	B	LF	WF	Clamp	Clamp Screw	Insert Screw	Wrench
TTH0295	SRGCR/L 1616 H06	16	16	16	100	20	-	-	TXS2506	TXW08
TTH0296	SRGCR/L 2020 K06	20	20	20	125	25	-	-	TXS2506	TXW08
TTH0297	SRGCR/L 1616 H08C	16	16	16	100	20	TTAP-4	TXS3511	TXS3008	TXW08
TTH0298	SRGCR/L 2020 K08C	20	20	20	125	25				
TTH0299	SRGCR/L 2525 M08C	25	25	25	150	32	TTAP-4	TXS3511	TXS3511	TXW15
TTH0300	SRGCR/L 1616 H10C	16	16	16	100	20				
TTH0301	SRGCR/L 2020 K10C	20	20	20	125	25				
TTH0302	SRGCR/L 2525 M10C	25	25	25	150	32				
TTH0303	SRGCR/L 3232 P10C	32	32	32	170	40	TTAP-1	TXS4011	TXS3511	TXW15
TTH0304	SRGCR/L 2020 K12C	20	20	20	125	20				
TTH0305	SRGCR/L 2525 M12C	25	25	25	150	25				
TTH0306	SRGCR/L 3232 P12C	32	32	32	170	32				

To order left hand add L to EDP code. Example: SRGCL 1616 H06 = TTH0295L



SCREW LOCK EXTERNAL HOLDERS

SRDCN

For RC.. positive inserts

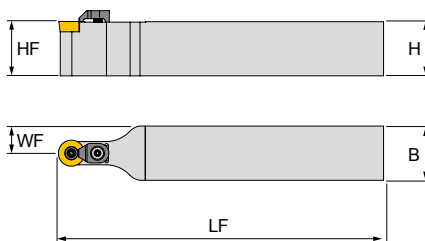
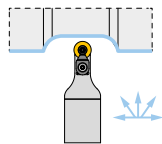
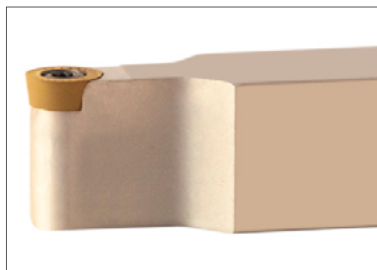

Insert

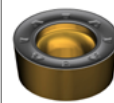
 RCMT 0602..
 RCMT 0803..
 RCMT 10T3..
 RCMT 1204..

EDP Code	Description	H	HF	B	LF	WF	Clamp	Clamp Screw	Insert Screw	Wrench
TTH0291	SRDCN 1616 H06	16	16	16	100	8	-	-	TXS2506	TXW08
TTH0101	SRDCN 2020 K06	20	20	20	125	10				
TTH0102	SRDCN 2525 M06	25	25	25	150	12.5				
TTH0292	SRDCN 1616 H08C	16	16	16	100	8	TTAP-4	TXS3511	TXS3008	TXW08
TTH0103	SRDCN 2020 K08C	20	20	20	125	10				
TTH0104	SRDCN 2525 M08C	25	25	25	150	12.5				
TTH0009	SRDCN 1616 H10C	16	16	16	100	8	TTAP-4	TXS3511	TXS3511	TXW15
TTH0010	SRDCN 2020 K10C	20	20	20	125	10				
TTH0105	SRDCN 2525 M10C	25	25	25	150	12.5				
TTH0293	SRDCN 3232 P10C	32	32	32	170	16	TTAP-1	TXS4011	TXS3511	TXW15
TTH0106	SRDCN 2020 K12C	20	20	20	125	10				
TTH0011	SRDCN 2525 M12C	25	25	25	150	12.5				
TTH0294	SRDCN 3232 P12C	32	32	32	170	16				



SCREW LOCK EXTERNAL HOLDERS

SSDCN

For SC.. positive inserts

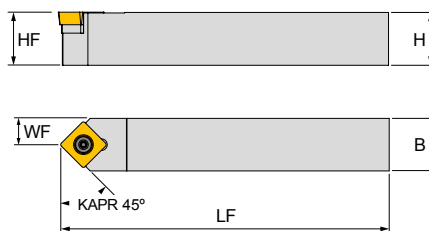
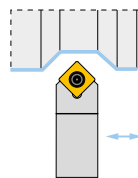

Insert	
	SCMT 09T3.. SCMT 1204..
	SCGT 09T3..

EDP Code	Description	H	HF	B	LF	WF	Shim	Shim Screw	Shim Key	Insert Screw	Wrench
TTH0012	SSDCN 1212 F09	12	12	12	80	6	-	-	-	TXS3511	TXW15
TTH0013	SSDCN 1616 H09	16	16	16	100	8	HSS09PA	HSAV35	HA3.5	TXS3514	TXW15
TTH0307	SSDCN 2020 K09	20	20	20	125	10					
TTH0308	SSDCN 1616 H12	16	16	16	100	8	HSS12PA	HSAV45.1	HA4.5	TXS4512	TXW20F
TTH0014	SSDCN 2020 K12	20	20	20	125	10		HSAV45		TXS4516	
TTH0015	SSDCN 2525 M12	25	25	25	150	12.5					



SCREW LOCK EXTERNAL HOLDERS

STFCR/L

For TC.. positive inserts



Right hand holder shown

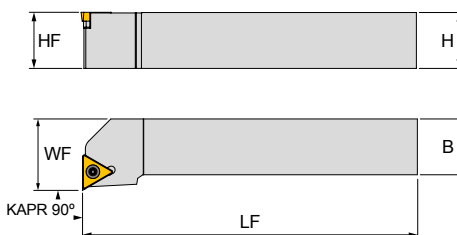
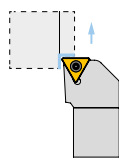

Insert	
	TCGT 1102.. TCGT 16T3..
	TCMT 1102.. TCMT 16T3..

EDP Code	Description	H	HF	B	LF	WF	Shim	Shim Screw	Shim Key	Insert Screw	Wrench
TTH0079	STFCR/L 1212 F11	12	12	12	80	16	-	-	-	TXS2506	TXW08
TTH0080	STFCR/L 1616 H11	16	16	16	100	20					
TTH0081	STFCR/L 1616 H16	16	16	16	100	20	HST16PA	HSAV35	HA3.5	TXS3514	TXW15
TTH0082	STFCR/L 2020 K16	20	20	20	125	25					
TTH0083	STFCR/L 2525 M16	25	25	25	150	32					
TTH0437	STFCR/L 3232 P16	32	32	32	170	40					

To order left hand add L to EDP code. Example: STFCL 1212 F11 = TTH0079L

STGCR/L

For TC.. positive inserts

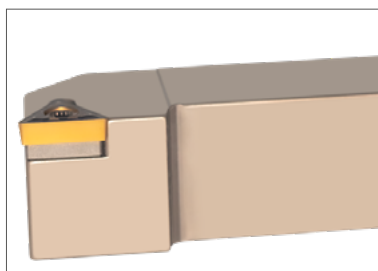

Right hand holder shown

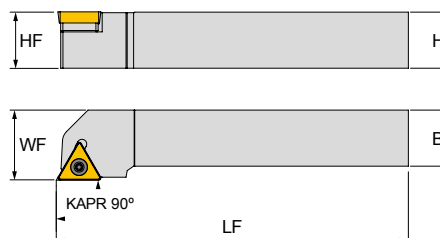
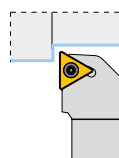

Insert	
	TCGT 1102.. TCGT 16T3..
	TCMT 1102.. TCMT 16T3..

EDP Code	Description	H	HF	B	LF	WF	Shim	Shim Screw	Shim Key	Insert Screw	Wrench
TTH0309	STGCR/L 1212 F11	12	12	12	80	16	-	-	-	TXS2506	TXW08
TTH0310	STGCR/L 1616 H11	16	16	16	100	20					
TTH0311	STGCR/L 1616 H16	16	16	16	100	20	HST16PA	HSAV35	HA3.5	TXS3514	TXW15
TTH0312	STGCR/L 2020 K16	20	20	20	125	25					
TTH0313	STGCR/L 2525 M16	25	25	25	150	32					
TTH0438	STGCR/L 3232 P16	32	32	32	170	40					

To order left hand add L to EDP code. Example: STGCL 1212 F11 = TTH0309L



SCREW LOCK EXTERNAL HOLDERS

SVJBR/L

For VB.. positive inserts

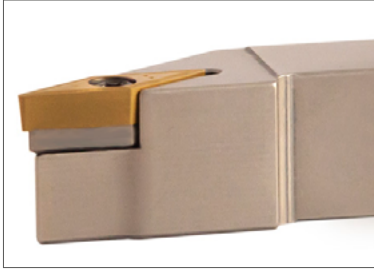

Right hand holder shown

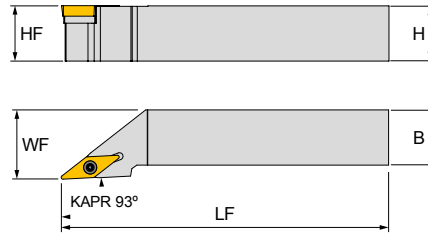
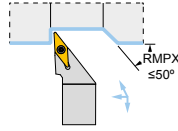

Insert	
	VBGT 1103.. VBMT 1103..
	VBMT 1604..

EDP Code	Description	H	HF	B	LF	WF	Shim	Shim Screw	Shim Key	Insert Screw	Wrench
TTH0439	SVJBR/L 1212 F11	12	12	12	80	16	-	-	-	TXS2506	TXW08
TTH0440	SVJBR/L 1616 H11	16	16	16	100	20					
TTH0441	SVJBR/L 2020 K11	20	20	20	125	25					
TTH0086	SVJBR/L 1616 H16	16	16	16	100	20	HSV16PA	HSAV35.1	HA3.5	TXS3512.1	TXW15
TTH0087	SVJBR/L 2020 K16	20	20	20	125	25		HSAV35		TXS3514	
TTH0088	SVJBR/L 2525 M16	25	25	25	150	32					
TTH0314	SVJBR/L 3232 P16	32	32	32	170	40					

To order left hand add L to EDP code. Example: SVJBL 1212 F11 = TTH0439L



SCREW LOCK EXTERNAL HOLDERS

SVJCR/L

For VC.. positive inserts



Right hand holder shown

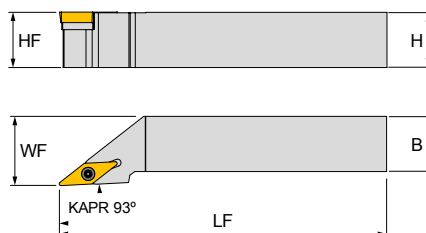
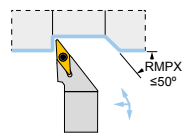

Insert	
	VCGT 1103.. VCGT 1604..
	VCMT 1103.. VCMT 1604..

EDP Code	Description	H	HF	B	LF	WF	Shim	Shim Screw	Shim Key	Insert Screw	Wrench
TTH0162	SVJCR/L 1212 F11	12	12	12	80	16	-	-	-	TXS2506	TXW08
TTH0163	SVJCR/L 1616 H11	16	16	16	100	20					
TTH0164	SVJCR/L 2020 K11	20	20	20	125	25					
TTH0315	SVJCR/L 2525 M11	25	25	25	150	32					
TTH0316	SVJCR/L 1212 F16	12	12	12	80	16	HSV16PA	HSAV35	HA3.5	TXS3514	TXW15
TTH0016	SVJCR/L 2020 K16	20	20	20	125	25					
TTH0017	SVJCR/L 2525 M16	25	25	25	150	32					
TTH0018	SVJCR/L 3232 P16	32	32	32	170	40					

To order left hand add L to EDP code. Example: SVJCL 1212 F11 = TTH0162L

SVVCN

For VC.. positive inserts

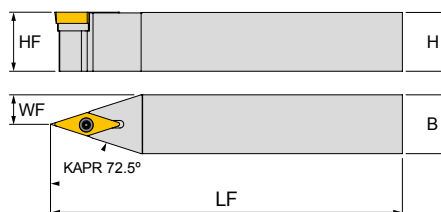
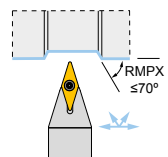
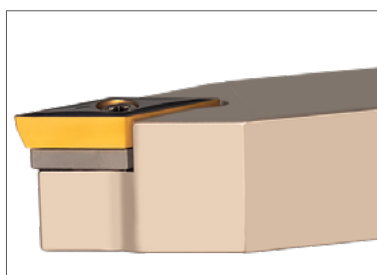

Insert	
	VCGT 1103.. VCGT 1604..
	VCMT 1103.. VCMT 1604..

EDP Code	Description	H	HF	B	LF	WF	Shim	Shim Screw	Shim Key	Insert Screw	Wrench
TTH0317	SVVCN 1212 F11	12	12	12	80	6	-	-	-	TXS2506	TXW08
TTH0318	SVVCN 1616 H11	16	16	16	100	8					
TTH0319	SVVCN 2020 K11	20	20	20	125	10					
TTH0320	SVVCN 2020 K16	20	20	20	125	10	HSV16PA	HSAV35	HA3.5	TXS3514	TXW15
TTH0321	SVVCN 2525 M16	25	25	25	150	12.5					
TTH0322	SVVCN 3232 P16	32	32	32	170	16					



HOLDERS FOR AUTOMATIC LATHES

SCACR/L

For CC.. positive inserts



Right hand holder shown

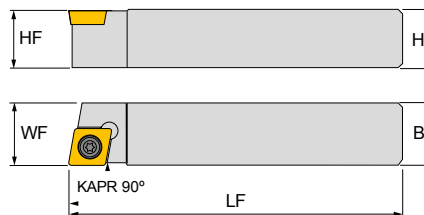
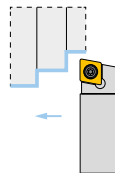

Insert

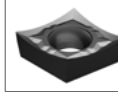

CCGT 0602..
CCGT 09T3..

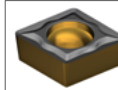

CCMT 0602..
CCMT 09T3..

EDP Code	Description	H	HF	B	LF	WF	Insert Screw	Wrench
TTH0165	SCACR/L 0808 X06-S	8	8	8	115	8	TXS2506	TXW08
TTH0166	SCACR/L 1010 K06-S	10	10	10	125	10		
TTH0167	SCACR/L 1212 G06-S	12	12	12	90	12		
TTH0168	SCACR/L 1212 K06-S	12	12	12	125	12		
TTH0169	SCACR/L 1616 F06-S	16	16	16	75	16		
TTH0170	SCACR/L 1616 K06-S	16	16	16	125	16		
TTH0171	SCACR/L 1212 G09-S	12	12	12	90	12	TXS3511	TXW15
TTH0172	SCACR/L 1212 K09-S	12	12	12	125	12		
TTH0173	SCACR/L 1616 F09-S	16	16	16	75	16		
TTH0174	SCACR/L 1616 K09-S	16	16	16	125	16		
TTH0175	SCACR/L 2020 K09-S	20	20	20	125	20		

To order left hand add L to EDP code. Example: SCACL 0808 X06-S = TTH0165L



HOLDERS FOR AUTOMATIC LATHES

SCLCR/L

For CC.. positive inserts



Right hand holder shown

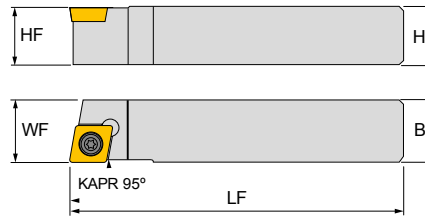
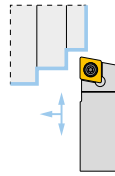

Insert

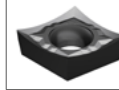

CCGT 0602..
CCGT 09T3..

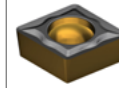

CCMT 0602..
CCMT 09T3..

EDP Code	Description	H	HF	B	LF	WF	Insert Screw	Wrench
TTH0176	SCLCR/L 0808 X06-S	8	8	8	115	8	TXS2506	TXW08
TTH0177	SCLCR/L 1010 X06-S	10	10	10	115	10		
TTH0178	SCLCR/L 1212 G06-S	12	12	12	90	12		
TTH0179	SCLCR/L 1212 K06-S	12	12	12	125	12		
TTH0180	SCLCR/L 1212 X06-S	12	12	12	130	12		
TTH0181	SCLCR/L 1616 F06-S	16	16	16	75	16		
TTH0182	SCLCR/L 1616 X06-S	16	16	16	130	16		
TTH0183	SCLCR/L 1212 G09-S	12	12	12	90	12	TXS3511	TXW15
TTH0184	SCLCR/L 1212 X09-S	12	12	12	130	12		
TTH0185	SCLCR/L 1616 F09-S	16	16	16	75	16		
TTH0186	SCLCR/L 1616 G09-S	16	16	16	90	16		
TTH0187	SCLCR/L 1616 X09-S	16	16	16	115	16		
TTH0188	SCLCR/L 2020 X09-S	20	20	20	120	20		

To order left hand add L to EDP code. Example: SCLCL 0808 X06-S = TTH0176L

SCLCR/L THROUGH COOLANT

For CC.. positive inserts

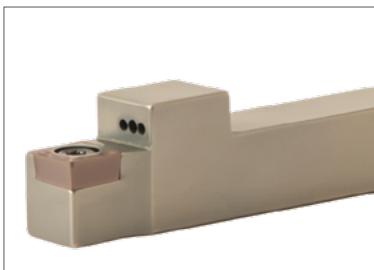

Right hand holder shown

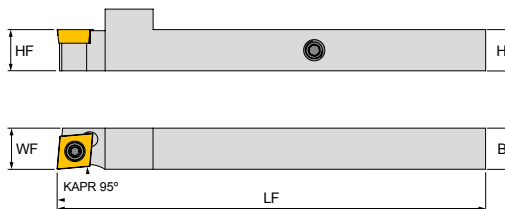
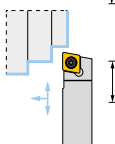

Insert

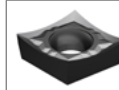

CCGT 09T3..

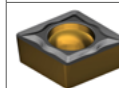

CCMT 09T3..

EDP Code	Description	H	HF	B	LF	WF	Set Screw	Insert Screw	Wrench
TTH0372	SCLCR/L 1212 K09-STC	12	12	12	125	12	HXS0604	TXS3511	TXW15
TTH0373	SCLCR/L 1616 K09-STC	16	16	16	125	16	HXS0805		

To order left hand add L to EDP code. Example: SCLCL 1212 K09-STC = TTH0372L



HOLDERS FOR AUTOMATIC LATHES

SDACR/L

For DC.. positive inserts



Right hand holder shown

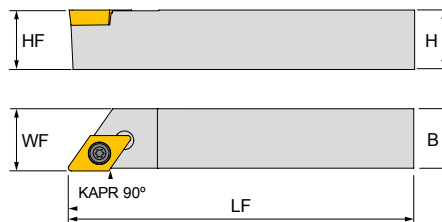
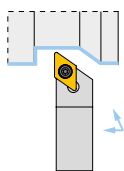

Insert	
	DCGT 0702.. DCGT 11T3..
	DCMT 0702.. DCMT 11T3..

EDP Code	Description	H	HF	B	LF	WF	Insert Screw	Wrench
TTH0189	SDACR/L 0808 X07-S	8	8	8	115	8	TXS2506	TXW08
TTH0190	SDACR/L 1010 K07-S	10	10	10	125	10		
TTH0191	SDACR/L 1212 G07-S	12	12	12	90	12		
TTH0192	SDACR/L 1212 K07-S	12	12	12	125	12		
TTH0193	SDACR/L 1616 F07-S	16	16	16	75	16		
TTH0194	SDACR/L 1616 K07-S	16	16	16	125	16		
TTH0195	SDACR/L 1212 G11-S	12	12	12	90	12	TXS3511	TXW15
TTH0196	SDACR/L 1212 K11-S	12	12	12	125	12		
TTH0197	SDACR/L 1616 F11-S	16	16	16	75	16		
TTH0198	SDACR/L 1616 K11-S	16	16	16	125	16		
TTH0199	SDACR/L 2020 K11-S	20	20	20	125	20		

To order left hand add L to EDP code. Example: SDACL 0808 X07-S = TTH0189L



HOLDERS FOR AUTOMATIC LATHES

SDJCR/L

For DC.. positive inserts



Right hand holder shown

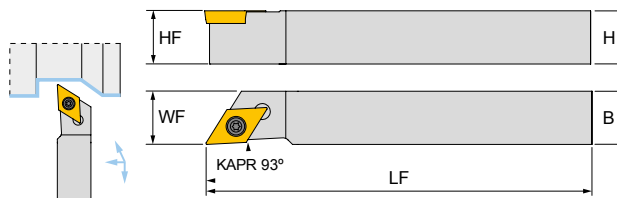

Insert	
	DCGT 0702.. DCMT 11T3..
	DCMT 0702.. DCMT 11T3..

EDP Code	Description	H	HF	B	LF	WF	Insert Screw	Wrench
TTH0200	SDJCR/L 0808 X07-S	8	8	8	115	8	TXS2506	TXW08
TTH0201	SDJCR/L 1010 X07-S	10	10	10	115	10		
TTH0202	SDJCR/L 1212 G07-S	12	12	12	90	12		
TTH0203	SDJCR/L 1212 X07-S	12	12	12	130	12		
TTH0204	SDJCR/L 1616 F07-S	16	16	16	75	12		
TTH0205	SDJCR/L 1616 X07-S	16	16	16	130	16		
TTH0206	SDJCR/L 2020 X07-S	20	20	20	120	20	TXS3511	TXW15
TTH0207	SDJCR/L 1212 G11-S	12	12	12	90	12		
TTH0208	SDJCR/L 1212 K11-S	12	12	12	125	12		
TTH0209	SDJCR/L 1212 X11-S	12	12	12	130	12		
TTH0210	SDJCR/L 1616 F11-S	16	16	16	75	16		
TTH0211	SDJCR/L 1616 K11-S	16	16	16	125	16		
TTH0212	SDJCR/L 1616 X11-S	16	16	16	130	16		
TTH0371	SDJCR/L 2020 X11-S	20	20	20	130	16		

To order left hand add L to EDP code. Example: SDJCL 0808 X07-S = TTH0200L

SDJCR/L THROUGH COOLANT

For DC.. positive inserts

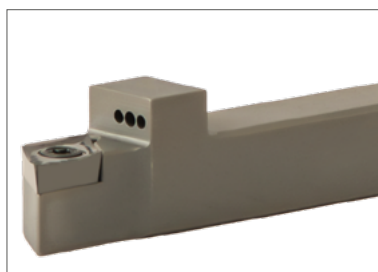

Right hand holder shown

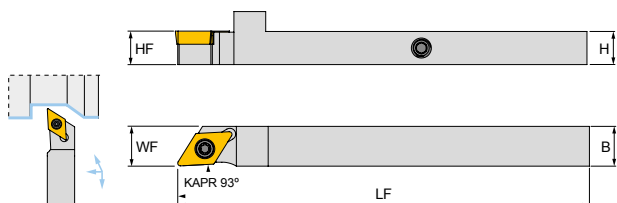

Insert	
	DCGT 0702.. DCMT 11T3..
	DCMT 0702.. DCMT 11T3..

EDP Code	Description	H	HF	B	LF	WF	Set Screw	Insert Screw	Wrench
TTH0374	SDJCR/L 0810 G07-STC	8	8	10	90	10	HXS0604	TXS2506	TXW08
TTH0375	SDJCR/L 1010 K07-STC	10	10	10	125	10			
TTH0376	SDJCR/L 1012 K11-STC	10	12	12	125	12	HXS0805	TXS3511	TXW15
TTH0377	SDJCR/L 1212 K11-STC	12	12	12	125	12			
TTH0378	SDJCR/L 1616 K11-STC	16	16	16	125	16			

To order left hand add L to EDP code. Example: SDJCL 0810 G07-STC = TTH0374L



HOLDERS FOR AUTOMATIC LATHES

STGCR/L

For TC.. positive inserts

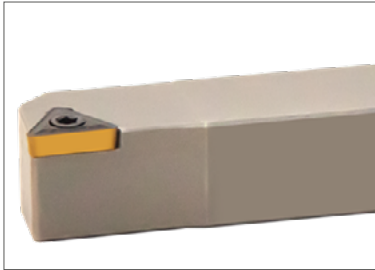

Right hand holder shown

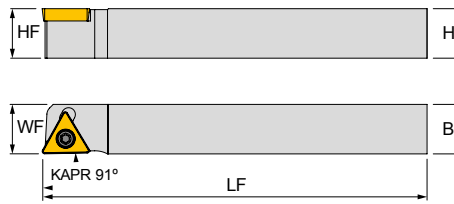
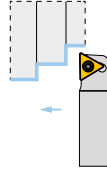

Insert	
	TCGT 1102.. TCMT 1102..
	TCGT 16T3.. TCMT 16T3..

EDP Code	Description	H	HF	B	LF	WF	Insert Screw	Wrench
TTH0214	STGCR/L 1216 K11-S	12	12	16	125	16	TXS2506	TXW08
TTH0215	STGCR/L 1616 K11-S	16	16	16	125	16		
TTH0216	STGCR/L 1216 K16-S	12	12	16	125	16	TXS3511	TXW15
TTH0217	STGCR/L 1616 K16-S	16	16	16	125	16		

To order left hand add L to EDP code. Example: STGCL 1216 K11-S = TTH0214L

STGCR/L THROUGH COOLANT

For TC.. positive inserts

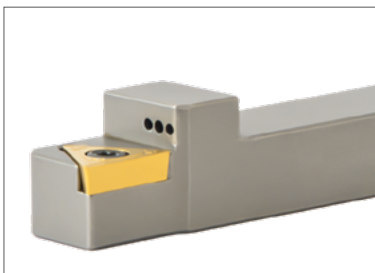

Right hand holder shown

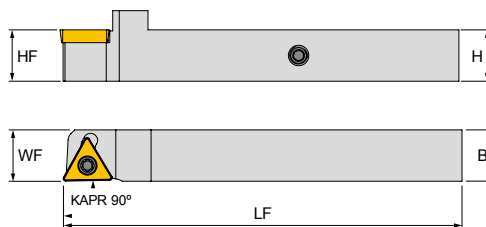
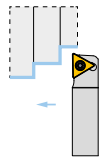

Insert	
	TCGT 16T3..
	TCMT 16T3..

EDP Code	Description	H	HF	B	LF	WF	Set Screw	Shim	Shim Screw	Insert Screw	Wrench
TTH0379	STGCR/L 1216 K16-STC	12	12	16	125	16	HXS0604	HST16PA	HSAV35	TXS3514	TXW15
TTH0380	STGCR/L 1616 K16-STC	16	16	16	125	16	HXS0805				

To order left hand add L to EDP code. Example: STGCL 1216 K16-STC = TTH0379L



HOLDERS FOR AUTOMATIC LATHES

SVACR/L

For VC.. positive inserts



Right hand holder shown

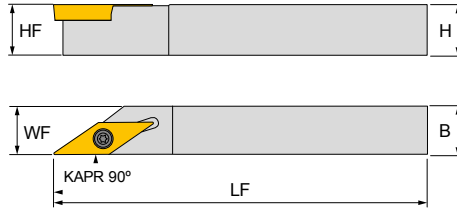
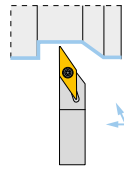

Insert	
	VCMT 1103.. VCMT 1604..
	VCGT 1103.. VCGT 1604..

EDP Code	Description	H	HF	B	LF	WF	Insert Screw	Wrench
TTH0218	SVACR/L 0808 X11-S	8	8	8	115	8	TXS2506	TXW08
TTH0219	SVACR/L 1010 K11-S	10	10	10	125	10		
TTH0220	SVACR/L 1212 G11-S	12	12	12	90	12		
TTH0221	SVACR/L 1212 K11-S	12	12	12	125	12		
TTH0222	SVACR/L 1616 F11-S	16	16	16	75	16		
TTH0223	SVACR/L 1616 K11-S	16	16	16	125	16		
TTH0224	SVACR/L 2020 K11-S	20	20	20	125	20		
TTH0225	SVACR/L 1212 K16-S	12	12	12	125	12	TXS3511	TXW15
TTH0226	SVACR/L 1616 K16-S	16	16	16	125	16		

To order left hand add L to EDP code. Example: SVACL 0808 X11-S = TTH0218L



HOLDERS FOR AUTOMATIC LATHES

SVJCR/L

For VC.. positive inserts

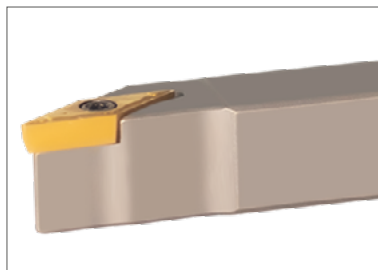

Right hand holder shown

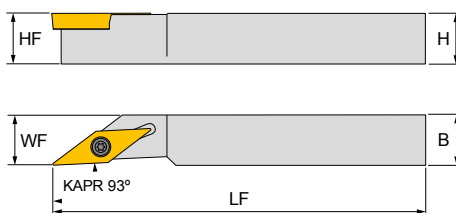
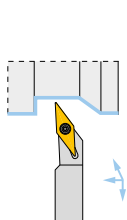

Insert	
	VCMT 1103..
	VCGT 1103..

EDP Code	Description	H	HF	B	LF	WF	Insert Screw	Wrench
TTH0227	SVJCR/L 0808 X11-S	8	8	8	115	8	TXS2506	TXW08
TTH0228	SVJCR/L 1010 K11-S	10	10	10	125	10		
TTH0229	SVJCR/L 1212 G11-S	12	12	12	90	12		
TTH0230	SVJCR/L 1212 K11-S	12	12	12	125	12		
TTH0231	SVJCR/L 1616 F11-S	16	16	16	75	16		
TTH0232	SVJCR/L 1616 K11-S	16	16	16	125	16		
TTH0233	SVJCR/L 2020 K11-S	20	20	20	125	20		

To order left hand add L to EDP code. Example: SVJCL 0808 X11-S = TTH0227L

SVJCR/L THROUGH COOLANT

For VC.. positive inserts

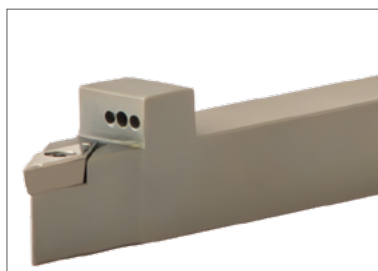

Right hand holder shown

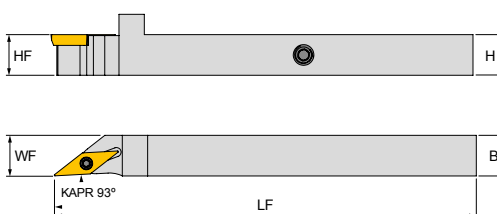
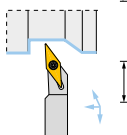

Insert	
	VCMT 1103..
	VCGT 1103..

EDP Code	Description	H	HF	B	LF	WF	Set Screw	Insert Screw	Wrench
TTH0381	SVJCR/L 1212 K11-STC	12	12	12	125	12	HXS0604	TXS2506	TXW08
TTH0382	SVJCR/L 1616 K11-STC	16	16	16	125	16	HXS0805		

To order left hand add L to EDP code. Example: SVJCL 1212 K11-STC = TTH0381L



EASY CHANGE HOLDERS FOR AUTOMATIC LATHES

MSTB-EC

Through Coolant holder

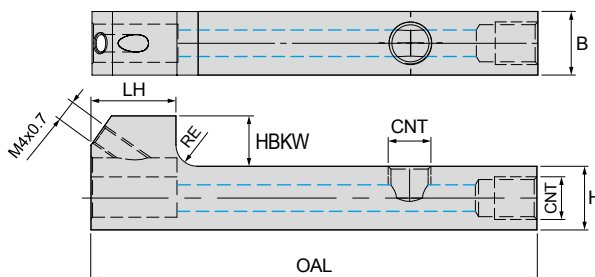
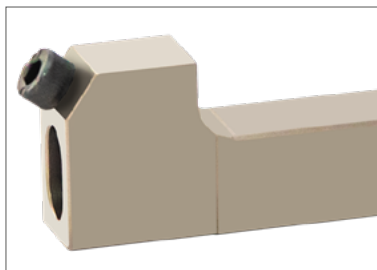

EDP Code	Description	H	B	RE	HBKW	LH	OAL	CNT	Screw	Set Screw
TTH0234	MSTB 1212-EC	12	12	4	9.5	16	84	M8 x 1.0	M4X12IMC	HXS0805
TTH0235	MSTB 1616-EC	16	16	1	5.5	16	90			

SDJCR/L-EC

For DC.. positive inserts

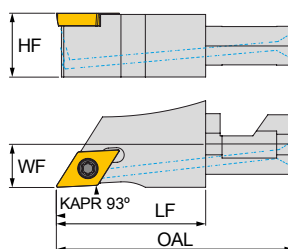
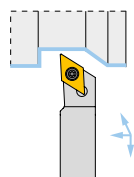
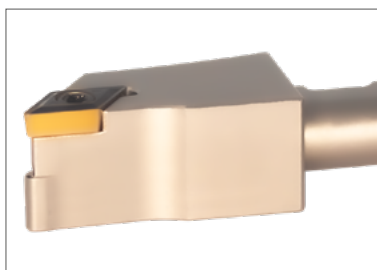

Insert	
	DCGT 0702.. DCGT 11T3..
	DCMT 0702.. DCMT 11T3..

Repeatability ±0.01mm. Right hand holder shown

EDP Code	Description	HF	WF	LF	OAL	Insert Screw	Wrench
TTH0236	SDJCR/L 12-07-EC	11.8	8	27.3	43.3	TXS2506	TXW08
TTH0237	SDJCR/L 16-07-EC	15.8	8	27.3	43.3		
TTH0238	SDJCR/L 12-11-EC	11.8	8	27.3	43.3	TXS3511	TXW15
TTH0239	SDJCR/L 16-11-EC	15.8	8	27.3	43.3		

To order left hand add L to EDP code. Example: SDJCL 12-07-TC = TTH0236L

SVJCR/L-EC

For VC.. positive inserts

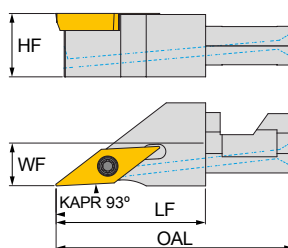
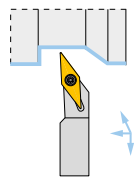
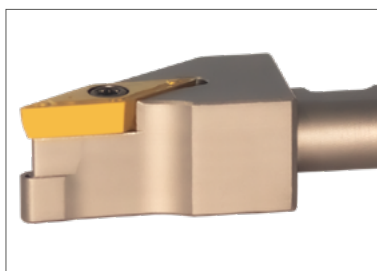

Insert	
	VCGT 1103..
	VCMT 1103..

Repeatability ±0.01mm. Right hand holder shown

EDP Code	Description	HF	WF	LF	OAL	Insert Screw	Wrench
TTH0240	SVJCR/L 12-11-EC	11.8	8	27.3	43.3	TXS2506	TXW08
TTH0241	SVJCR/L 16-11-EC	15.8	8	27.3	43.3		

To order left hand add L to EDP code. Example: SVJCL 12-11-TC = TTH0240L



LEVER LOCK INTERNAL HOLDERS

- PCLNR/L

For CN.. negative inserts



Right hand holder shown - additional security clamp

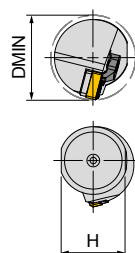
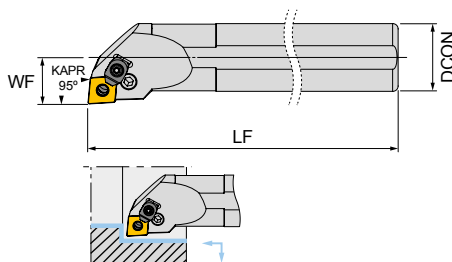

Insert	
	CNGG 1204..
	CNMA 1204.. CNMA 1606.. CNMA 1906..
	CNMG 1204.. CNMG 1606.. CNMG 1906..
	CNMM 1204.. CNMM 1606.. CNMM 1906..

EDP Code	Description		DCON	DMIN	H	LF	WF	Clamp	Clamp Screw	Shim	Shim Pin	Lever	Lever Screw	Wrench	Key
TTH0093	A25R PCLNR/L 12C	♦	25	32	23	200	17	TTAP-1	TXS4011	HPC12NA	HAY461	HL441	HLV440	TXW15	HA3
TTH0451	A25S PCLNR/L 12C	♦	25	32	23	250	17								
TTH0094	A32S PCLNR/L 12C	♦	32	40	30	250	22								
TTH0452	A32T PCLNR/L 12C	♦	32	40	30	300	22								
TTH0453	A40T PCLNR/L 12C	♦	40	50	37.5	300	27								
TTH0454	A50U PCLNR/L 12C	♦	50	63	47	350	35								
TTH0158	A32S PCLNR/L 16C	♦	32	40	30	250	22	TTAP-2	HBI6	HPC16NA	HAY464	HL443	HLV442	-	HA3
TTH0159	A40T PCLNR/L 16C	♦	40	50	37.5	300	27								
TTH0323	A50U PCLNR/L 16C	♦	50	63	47	350	35								
TTH0160	A40T PCLNR/L 19C	♦	40	50	37.5	300	27	TTAP-2	HBI6	HPC19NA	HAY465	HL444	HLV443	-	HA4
TTH0161	A50U PCLNR/L 19C	♦	50	63	47	350	35								
TTH0442	S25S PCLNR/L 12C	✘	25	32	23	250	17	TTAP-1	TXS4011	HPC12NA	HAY461	HL441	HLV440	TXW15	HA3
TTH0443	S32T PCLNR/L 12C	✘	32	40	30	300	22								
TTH0444	S40U PCLNR/L 12C	✘	40	50	37.5	350	27								
TTH0445	S50V PCLNR/L 12C	✘	50	63	47	400	35								
TTH0446	S32T PCLNR/L 16C	✘	32	40	30	300	22	TTAP-2	HBI6	HPC16NA	HAY464	HL443	HLV442	-	HA3
TTH0447	S40U PCLNR/L 16C	✘	40	50	37.5	350	27								
TTH0448	S50V PCLNR/L 16C	✘	50	63	47	400	35								
TTH0449	S40U PCLNR/L 19C	✘	40	50	37.5	350	27	TTAP-2	HBI6	HPC19NA	HAY465	HL444	HLV443	-	HA4
TTH0450	S50V PCLNR/L 19C	✘	50	63	47	400	35								

To order left hand add L to EDP code. Example: A25R PCLNL 12C = TTH0093L



LEVER LOCK INTERNAL HOLDERS

- PDUNR/L For DN.. negative inserts



Right hand holder shown

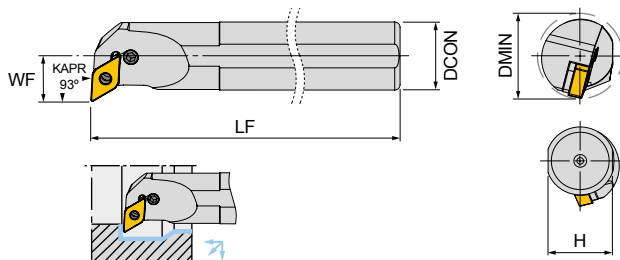

Insert	
	DNGG 1506..
	DNMA 1506..
	DNMG 1104.. DNMG 1504.. DNMG 1506..
	DNMM 1506..

EDP Code	Description	⚡	DCON	DMIN	H	LF	WF	Shim	Shim Pin	Lever	Lever Screw	Wrench	Key
TTH0324	A20P PDUNR/L 11	⚡	20	25	18.3	170	13	HPD11NA	HAY463	HL440	HLV410	-	HA2.5
TTH0325	A25R PDUNR/L 11	⚡	25	32	23	200	17				HLV420		
TTH0455	A25S PDUNR/L 11	⚡	25	32	23	250	17						
TTH0326	A32S PDUNR/L 11	⚡	32	40	30	250	22	HPD15NA	HAY461	HL442	HLV441	-	HA3
TTH0327	A32S PDUNR/L 15	⚡	32	40	30	250	22						
TTH0328	A40T PDUNR/L 15	⚡	40	50	37.5	300	27						
TTH0329	A50U PDUNR/L 15	⚡	50	63	47	350	35						
TTH0456	S20R PDUNR/L 11	X	20	25	18.3	200	13				HPD11NA		
TTH0457	S25S PDUNR/L 11	X	25	32	23	250	17	HLV420					
TTH0458	S25S PDUNR/L 15	X	25	32	23	250	19	HPD15NA	HAY461	HL442	HLV440	-	HA3
TTH0459	S32T PDUNR/L15	X	32	40	30	300	22				HLV441		
TTH0460	S40U PDUNR/L 15	X	40	50	37.5	350	27						
TTH0461	S50V PDUNR/L 15	X	50	63	47	400	35						

To order left hand add L to EDP code. Example: A20P PDUNL 11 = TTH0324L

For DNMG 1504 inserts, order additional shim HPD15XA

- PDXNR/L For DN.. negative inserts



Right hand holder shown

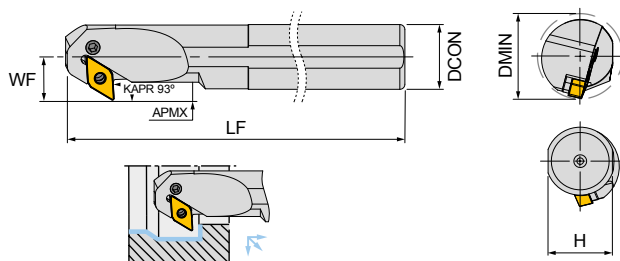

Insert	
	DNGG 1506..
	DNMA 1506..
	DNMG 1104.. DNMG 1504.. DNMG 1506..
	DNMM 1506..

EDP Code	Description	⚡	DCON	DMIN	H	LF	WF	APMX	Shim	Shim Pin	Lever	Lever Screw	Wrench	Key
TTH0462	A32S PDXNR/L 15	⚡	32	40	30	250	22	12	HPD15NA	HAY461	HL442	HLV440	-	HA3
TTH0463	A40T PDXNR/L 15	⚡	40	50	37.5	300	27	14				HLV441		
TTH0464	A50U PDXNR/L 15	⚡	50	63	47	350	35	19						
TTH0465	S32T PDXNR/L15	X	50	63	47	350	35	12	HPD15NA	HAY461	HL442	HLV440	-	HA3
TTH0466	S40U PDXNR/L 15	X	50	63	47	350	35	14				HLV441		
TTH0467	S50V PDXNR/L 15	X	50	63	47	350	35	19						

To order left hand add L to EDP code. Example: A32S PDXNL 15 = TTH0462L

For DNMG 1504 inserts, order additional shim HPD15XA



LEVER LOCK INTERNAL HOLDERS

- PSKNR/L

For SN.. negative inserts



Right hand holder shown - additional security clamp

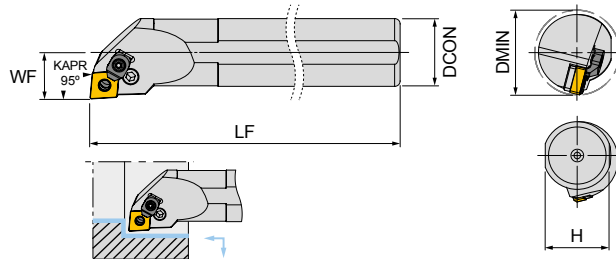

Insert	
	SNMA 1204.. SNMA 1506..
	SNMG 1204..
	SNMM 1506..

EDP Code	Description	◆	DCON	DMIN	H	LF	WF	Clamp	Clamp Screw	Shim	Shim Pin	Lever	Lever Screw	Wrench	Key
TTH0468	A25R PSKNR/L 12C	◆	25	32	23	200	17	TTAP-1	TXS4011	HPS12NA	HAY461	HL441	HLV440	TXW15	HA3
TTH0469	A32S PSKNR/L 12C	◆	32	40	30	250	22						HLV441		
TTH0470	A40T PSKNR/L 12C	◆	40	50	37.5	300	27								
TTH0471	A50U PSKNR/L 12C	◆	50	63	47	350	35								
TTH0472	A32S PSKNR/L 15C	◆	32	40	30	250	22	TTAP-2	HBI6	HPS15NA	HAY464	HL443	HLV442	-	HA3
TTH0473	A40T PSKNR/L 15C	◆	40	50	37.5	300	27								
TTH0474	A50U PSKNR/L 15C	◆	50	63	47	350	35								
TTH0475	S25S PSKNR/L 12C	✗	25	32	23	250	17	TTAP-1	TXS4011	HPS12NA	HAY461	HL441	HLV440	TXW15	HA3
TTH0476	S32T PSKNR/L 12C	✗	32	40	30	300	22						HLV441		
TTH0477	S40U PSKNR/L 12C	✗	40	50	37.5	350	27								
TTH0478	S50V PSKNR/L 12C	✗	50	63	47	400	35								
TTH0479	S32T PSKNR/L 15C	✗	32	40	30	300	22	TTAP-2	HBI6	HPS15NA	HAY464	HL443	HLV442	-	HA3
TTH0480	S40U PSKNR/L 15C	✗	40	50	37.5	350	27								
TTH0481	S50V PSKNR/L 15C	✗	50	63	47	400	35								

To order left hand add L to EDP code. Example: A25R PSKNL 12C = TTH0468L



LEVER LOCK INTERNAL HOLDERS

- PTUNR/L

For TN.. negative inserts



Right hand holder shown - additional security clamp

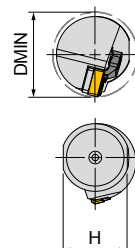
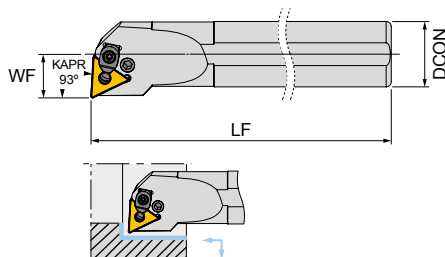

Insert	
	TNMA 1604..
	TNMG 1604.. TNMG 2204..
	TNUX 1604..

EDP Code	Description	◆	DCON	DMIN	H	LF	WF	Clamp	Clamp Screw	Shim	Shim Pin	Lever	Lever Screw	Wrench	Key
TTH0482	A16M PTUNR/L 16	◆	16	20	14.8	150	11	-	-	-	HAY467	HL447	HLV445	-	HA2.5
TTH0483	A20P PTUNR/L 16	◆	20	25	18.3	170	13	-	-	-	HAY467	HL447	HLV410	-	
TTH0484	A25R PTUNR/L 16C	◆	25	32	23	200	17	TTAP-1	TXS4011	HPT16NAP	HAY463	HL440	HLV420	TXW15	
TTH0485	A32S PTUNR/L 16C	◆	32	40	30	250	22								
TTH0486	A40T PTUNR/L 16C	◆	40	50	37.5	300	27								
TTH0487	A32S PTUNR/L 22C	◆	32	40	30	250	22	TTAP-1	TXS4011	HPT22NA	HAY461	HL441	HLV441	TXW15	HA3
TTH0488	A40T PTUNR/L 22C	◆	40	50	37.5	300	27								
TTH0489	S16P PTUNR/L 16	✗	16	20	14.8	170	11	-	-	-	HAY467	HL447	HLV445	-	HA2.5
TTH0490	S20R PTUNR/L 16	✗	20	25	18.3	200	13	-	-	-	HAY467	HL447	HLV410	-	
TTH0491	S25S PTUNR/L 16C	✗	25	32	23	250	17	TTAP-1	TXS4011	HPT16NAP	HAY463	HL440	HLV420	TXW15	
TTH0492	S32T PTUNR/L 16C	✗	32	40	30	300	22								
TTH0493	S40U PTUNR/L 16C	✗	40	50	37.5	350	27								
TTH0494	S32T PTUNR/L 22C	✗	32	40	30	300	22	TTAP-1	TXS4011	HPT22NA	HAY461	HL441	HLV441	TXW15	HA3
TTH0495	S40U PTUNR/L 22C	✗	40	50	37.5	350	27								
TTH0496	S50V PTUNR/L 22C	✗	50	63	47	400	35								

To order left hand add L to EDP code. Example: A16M PTUNL 16 = TTH0482L



LEVER LOCK INTERNAL HOLDERS

- PWLNR/L For WN.. negative inserts



Right hand holder shown - additional security clamp

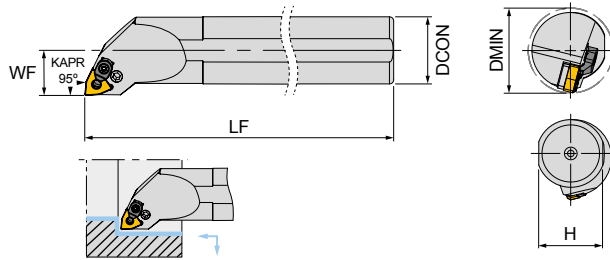

Insert	
	WNGG 0804..
	WNMA 0804..
	WNMG 0604.. WNMG 0804..

EDP Code	Description	◆	DCON	DMIN	H	LF	WF	Clamp	Clamp Screw	Shim	Shim Pin	Lever	Lever Screw	Wrench	Key
TTH0330	A16M PWLNR/L 06	◆	16	20	14.8	150	11	-	-	-	HAY466	HL445	HLV444	-	HA2.5
TTH0331	A20P PWLNR/L 06	◆	20	25	18.3	170	13			HPW06NA	HAY463	HL440	HLV410		
TTH0332	A25R PWLNR/L 06	◆	25	32	23	200	17			HLV420					
TTH0333	A32S PWLNR/L 06	◆	32	40	30	250	22								
TTH0334	A25R PWLNR/L 08C	◆	25	32	23	200	17	TTAP-1	TXS4011	HPW08NA	HAY461	HL441	HLV441	TXW15	HA3
TTH0335	A32S PWLNR/L 08C	◆	32	40	30	250	22								
TTH0336	A40T PWLNR/L 08C	◆	40	50	37.5	300	27								
TTH0337	A50U PWLNR/L 08C	◆	50	63	47	350	35								
TTH0497	S20R PWLNR/L 06	✗	20	25	18.3	200	13	-	-	HPW06NA	HAY463	HL440	HLV410	-	HA2.5
TTH0498	S25S PWLNR/L 06	✗	25	32	23	250	17						HLV420		
TTH0499	S32T PWLNR/L 06	✗	32	40	30	300	22								
TTH0500	S25S PWLNR/L 08C	✗	25	32	23	250	17	TTAP-1	TXS4011	HPW08NA	HAY461	HL441	HLV441	TXW15	HA3
TTH0501	S32T PWLNR/L 08C	✗	32	40	30	300	22								
TTH0502	S40U PWLNR/L 08C	✗	40	50	37.5	350	27								
TTH0503	S50V PWLNR/L 08C	✗	50	63	47	400	35								

To order left hand add L to EDP code. Example: A16M PWLNL 06 = TTH0330L



SCREW LOCK INTERNAL HOLDERS

- SCLCR/L

For CC.. positive inserts

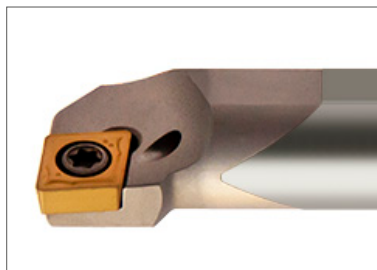

Right hand holder shown

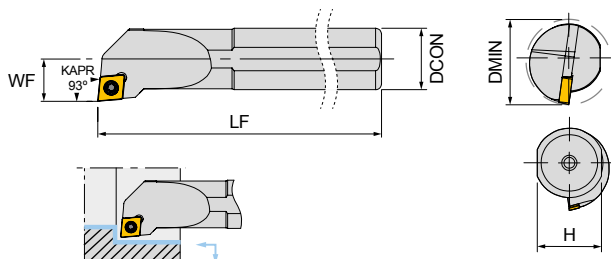

Insert	
	CCGT 0602.. CCGT 09T3.. CCGT 1204..
	CCMT 0602.. CCMT 09T3.. CCMT 1204..

EDP Code	Description		DCON	DMIN	H	LF	WF	Shim	Shim Screw	Shim Key	Insert Screw	Wrench
TTH0338	E08K SCLCR/L 06*	♦	8	11	7.5	125	6					
TTH0095	E10M SCLCR/L 06*	♦	10	13	9.5	150	7	-	-	-	TXS2506	TXW08
TTH0096	E12Q SCLCR/L 06*	♦	12	16	11	180	9					
TTH0097	E16R SCLCR/L 09*	♦	16	20	15	200	11	-	-	-	TXS3509	TXW15
TTH0339	E20S SCLCR/L 09*	♦	20	24	19	250	13					
TTH0062	A08H SCLCR/L 06	♦	8	11	7.3	100	6	-	-	-	TXS2506	TXW08
TTH0063	A10H SCLCR/L 06	♦	10	12	9	100	6					
TTH0064	A12H SCLCR/L 06	♦	12	16	11	100	9					
TTH0065	A12H SCLCR/L 09	♦	12	16	11	100	9					
TTH0066	A16M SCLCR/L 09	♦	16	20	15	150	11	-	-	-	TXS3509	TXW15
TTH0067	A20P SCLCR/L 09	♦	20	25	18	170	13					
TTH0340	A25R SCLCR/L 09	♦	25	32	23	200	17	HSC09PA	HSAV35.1	HA3.5	TXS3512.1	TXW15
TTH0341	A32S SCLCR/L 09	♦	32	40	30	250	22					
TTH0342	A25R SCLCR/L 12	♦	25	32	23	200	17	HSC12PA	HSAV45.1	HA4.5	TXS4512	TXW20F
TTH0019	S08H SCLCR/L 06	✘	8	11	7.3	100	6					
TTH0020	S10K SCLCR/L 06	✘	10	13	9	125	7	-	-	-	TXS2506	TXW08
TTH0021	S12K SCLCR/L 06	✘	12	16	11	125	9					
TTH0022	S16P SCLCR/L 06	✘	16	20	14.8	170	11					
TTH0023	S12K SCLCR/L 09	✘	16	20	14.8	125	11	-	-	-	TXS3509	TXW15
TTH0024	S16P SCLCR/L 09	✘	16	20	14.8	170	11					
TTH0025	S20R SCLCR/L 09	✘	20	25	18.3	200	13					
TTH0026	S25S SCLCR/L 09	✘	25	32	23	250	17	HSC09PA	HSAV35	HA3.5	TXS3513	TXW15
TTH0343	S32T SCLCR/L 09	✘	32	40	30	300	22		HSAV35.1		TXS3512.1	
TTH0344	S25S SCLCR/L 12	✘	25	32	23	250	17					
TTH0345	S32T SCLCR/L 12	✘	32	40	30	300	22	HSC12PA	HSAV45.1	HA4.5	TXS4512	TXW20F
TTH0346	S40U SCLCR/L 12	✘	40	50	37.5	350	27		HSAV45		TXS4516	

To order left hand add L to EDP code. Example: E08K SCLCL 06 = TTH0338L

*Carbide Shank



SCREW LOCK INTERNAL HOLDERS

- SDUCR/L

For DC.. positive inserts



Right hand holder shown

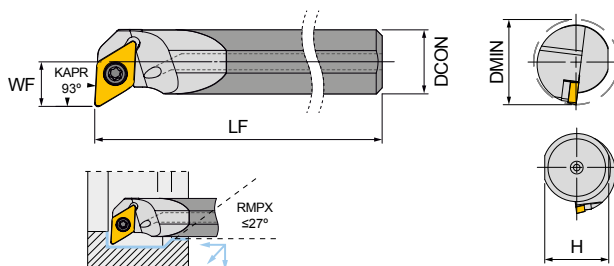

Insert	
	DCGT 0702.. DCGT 11T3..
	DCMT 0702.. DCMT 11T3..

EDP Code	Description		DCON	DMIN	H	LF	WF	Shim	Shim Screw	Shim Key	Insert Screw	Wrench
TTH0098	E10M SDUCR/L 07*	♦	10	13	9.5	150	8	-	-	-	TXS2506	TXW08
TTH0099	E12Q SDUCR/L 07*	♦	12	16	11	180	9	-	-	-	TXS2506	TXW08
TTH0100	E16R SDUCR/L 11*	♦	16	20	15	200	11	-	-	-	TXS3509	TXW15
TTH0347	E20S SDUCR/L 11*	♦	20	23	18.3	250	12	-	-	-	TXS3509	TXW15
TTH0348	A10H SDUCR/L 07	♦	10	13	9	100	8	-	-	-	TXS2506	TXW08
TTH0349	A12H SDUCR/L 07	♦	12	16	11	100	9	-	-	-	TXS2506	TXW08
TTH0350	A16M SDUCR/L 07	♦	16	20	14.8	150	11	-	-	-	TXS2506	TXW08
TTH0351	A20P SDUCR/L 07	♦	20	25	18.3	170	13	-	-	-	TXS2506	TXW08
TTH0352	A16M SDUCR/L 11	♦	16	20	14.8	150	11	-	-	-	TXS3509	TXW15
TTH0353	A20P SDUCR/L 11	♦	20	25	18.3	170	13	-	-	-	TXS3511	
TTH0354	A25R SDUCR/L 11	♦	25	32	23	200	17	HSD11PA	HSAV35.1	HA3.5	TXS3512.1	
TTH0355	A32S SDUCR/L 11	♦	32	40	30	250	22	HSD11PA	HSAV35	HA3.5	TXS3514	TXW15
TTH0356	S10K SDUCR/L 07	✘	10	13	9	125	8	-	-	-	TXS2506	TXW08
TTH0357	S12K SDUCR/L 07	✘	12	16	11	125	9	-	-	-	TXS2506	TXW08
TTH0358	S16P SDUCR/L 07	✘	16	20	14.8	170	11	-	-	-	TXS2506	TXW08
TTH0359	S20R SDUCR/L 07	✘	20	25	18.3	200	13	-	-	-	TXS2506	TXW08
TTH0360	S16P SDUCR/L 11	✘	16	20	14.8	170	11	-	-	-	TXS3509	TXW15
TTH0361	S20R SDUCR/L 11	✘	20	25	18.3	200	13	-	-	-	TXS3511	
TTH0362	S25S SDUCR/L 11	✘	25	32	23	250	17	HSD11PA	HSAV35.1	HA3.5	TXS3512.1	
TTH0363	S32T SDUCR/L 11	✘	32	40	30	300	22	HSD11PA	HSAV35	HA3.5	TXS3514	TXW15

To order left hand add L to EDP code. Example: E10M SDUCL 07 = TTH0098L

*Carbide Shank

SCREW LOCK INTERNAL HOLDERS

- SDQCR/L For DC.. positive inserts



Right hand holder shown

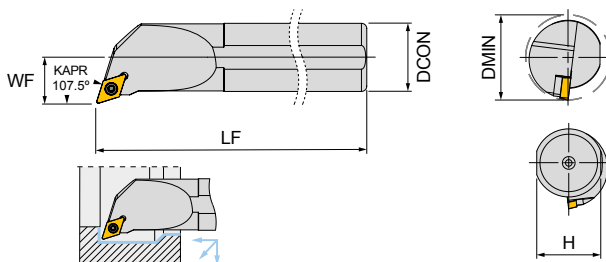

Insert	
	DCGT 0702.. DCMT 11T3..
	DCMT 0702.. DCMT 11T3..

EDP Code	Description	◆	DCON	DMIN	H	LF	WF	Shim	Shim Screw	Shim Key	Insert Screw	Wrench
TTH0074	S10K SDQCR/L 07	X	10	13	9	125	7	-	-	-	TXS2506	TXW08
TTH0075	S12K SDQCR/L 07	X	12	16	11	125	9	-	-	-	TXS2506	TXW08
TTH0076	S16P SDQCR/L 11	X	16	20	14.8	170	11	-	-	-	TXS3509	TXW15
TTH0077	S20R SDQCR/L 11	X	20	25	18.3	200	13	-	-	-	TXS3511	
TTH0078	S25S SDQCR/L 11	X	25	32	23	250	17	HSD11PA	HSAV35.1	HA3.5	TXS3513	

To order left hand add L to EDP code. Example: S10K SDQCL 07 = TTH0074L

- SDXCR/L For DC.. positive inserts

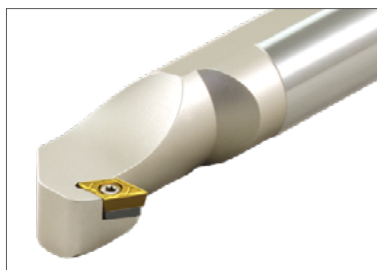

Right hand holder shown

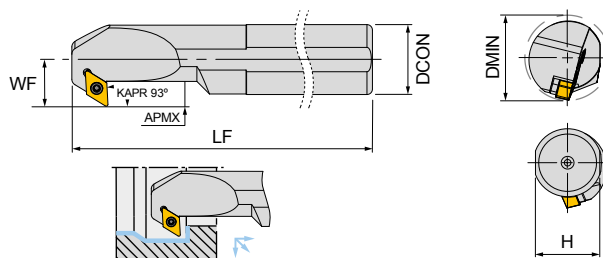

Insert	
	DCGT 0702.. DCMT 11T3..
	DCMT 0702.. DCMT 11T3..

EDP Code	Description	◆	DCON	DMIN	H	LF	WF	APMX	Shim	Shim Screw	Shim Key	Insert Screw	Wrench
TTH0504	A12H SDXCR/L 07	◆	12	16	11	100	9	4.5	-	-	-	TXS2506	TXW08
TTH0505	A16M SDXCR/L 07	◆	16	20	14.8	150	11	6.5	-	-	-	TXS2506	TXW08
TTH0506	A20P SDXCR/L 07	◆	20	25	18.3	170	13	6.5	-	-	-	TXS2506	TXW08
TTH0507	A16M SDXCR/L 11	◆	16	20	14.8	150	11	7.5	-	-	-	TXS3511	TXW15
TTH0508	A20P SDXCR/L 11	◆	20	25	18.3	170	13	7.5	-	-	-	TXS3511	
TTH0509	A25R SDXCR/L 11	◆	25	32	23	200	17	9	HSD11PA	HSAV35.1	HA3.5	TXS3514	
TTH0510	A32S SDXCR/L 11	◆	32	40	30	250	22	12.5		HSAV35			
TTH0511	S12K SDXCR/L 07	X	12	16	11	125	9	4.5	-	-	-	TXS2506	TXW08
TTH0512	S16P SDXCR/L 07	X	16	20	14.8	170	11	6.5	-	-	-	TXS2506	TXW08
TTH0513	S20R SDXCR/L 07	X	20	25	18.3	200	13	6.5	-	-	-	TXS2506	TXW08
TTH0514	S16P SDXCR/L 11	X	16	20	14.8	170	11	6.5	-	-	-	TXS3509	TXW15
TTH0515	S20R SDXCR/L 11	X	20	25	18.3	200	13	7.5	-	-	-	TXS3511	
TTH0516	S25S SDXCR/L 11	X	25	32	23	250	17	9	HSD11PA	HSAV35.1	HA3.5	TXS3514	
TTH0517	S32T SDXCR/L 11	X	32	40	30	300	22	12.5		HSAV35			

To order left hand add L to EDP code. Example: A12H SDXCL 07 = TTH0504L



SCREW LOCK INTERNAL HOLDERS

- SRGCR/L

For RC.. positive inserts



Right hand holder shown

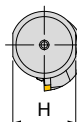
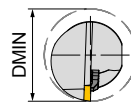
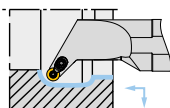
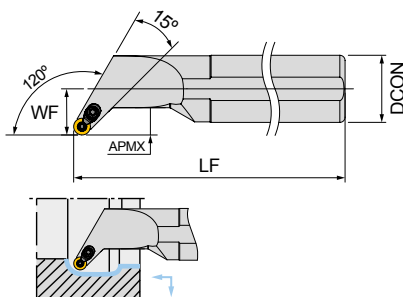

Insert

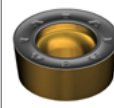

RCMT 0803..

EDP Code	Description		DCON	DMIN	H	LF	WF	APMX	Clamp	Clamp Screw	Clamp Key	Insert Screw	Wrench
TTH0518	A16M SRGCR/L 08	♦	16	20	14.8	150	11	7	-	-	-	TXS3008	TXW08
TTH0519	A20P SRGCR/L 08	♦	20	25	18.3	170	13	7	-	-	-		
TTH0520	A25R SRGCR/L 08C	♦	25	32	23	200	17	9.5	TTAP-3	TXS3511	TXW15		
TTH0521	A32S SRGCR/L 08C	♦	32	40	30	250	22	13	TTAP-3	TXS3511	TXW15	TXS3008	TXW08
TTH0522	S16P SRGCR/L 08	x	16	20	14.8	170	11	7	-	-	-		
TTH0523	S20R SRGCR/L 08	x	20	25	18.3	200	13	7	-	-	-		
TTH0524	S25S SRGCR/L 08C	x	25	32	23	250	17	9.5	TTAP-3	TXS3511	TXW15	TXS3008	TXW08
TTH0525	S32T SRGCR/L 08C	x	32	40	30	300	22	13	TTAP-3	TXS3511	TXW15		

To order left hand add L to EDP code. Example: A16M SRGCL 08 = TTH0518L



SCREW LOCK INTERNAL HOLDERS

- STUCR/L

For TC.. positive inserts



Right hand holder shown

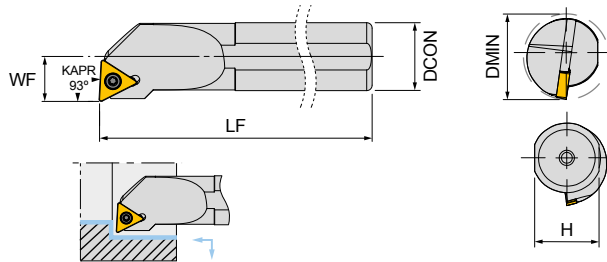

Insert	
	TCGT 1102.. TCGT 16T3..
	TCMT 1102.. TCMT 16T3..

EDP Code	Description		DCON	DMIN	H	LF	WF	Shim	Shim Screw	Shim Key	Insert Screw	Wrench
TTH0526	A12H STUCR/L 11	♦	12	16	11	100	9					
TTH0527	A16M STUCR/L 11	♦	16	20	14.8	150	11	-	-	-	TXS2506	TXW08
TTH0528	A20P STUCR/L 11	♦	20	25	18.3	170	13					
TTH0529	A16M STUCR/L 16	♦	16	20	14.8	150	11				TXS3509	TXW15
TTH0530	A20P STUCR/L 16	♦	20	25	18.3	170	13				TXS3511	
TTH0531	A25R STUCR/L 16	♦	25	32	23	200	17	HSD11PA	HSAV35.1	HA3.5	TXS3514	
TTH0532	A32S STUCR/L 16	♦	32	40	30	250	22		HSAV35			
TTH0533	S12K STUCR/L 11	✘	12	16	11	125	9					
TTH0534	S16P STUCR/L 11	✘	16	20	14.8	170	11	-	-	-	TXS2506	TXW08
TTH0535	S20R STUCR/L 11	✘	20	25	18.3	200	13					
TTH0536	S16P STUCR/L 16	✘	16	20	14.8	170	11				TXS3509	TXW15
TTH0537	S20R STUCR/L 16	✘	20	25	18.3	200	13				TXS3511	
TTH0538	S25S STUCR/L 16	✘	25	32	23	250	17	HSD11PA	HSAV35.1	HA3.5	TXS3514	
TTH0539	S32T STUCR/L 16	✘	32	40	30	300	22		HSAV35			

To order left hand add L to EDP code. Example: A12H STUCL 11 = TTH0526L



SCREW LOCK INTERNAL HOLDERS

- SVUCR/L

For VC.. positive inserts

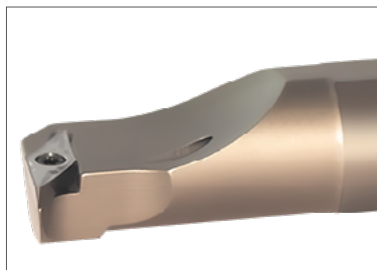

Right hand holder shown

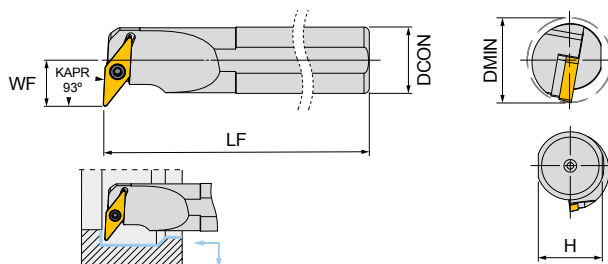

Insert	
	VCMT 1103.. VCMT 1604..
	VCGT 1103.. VCGT 1604..

EDP Code	Description	♦	DCON	DMIN	H	LF	WF	Shim	Shim Screw	Shim Key	Insert Screw	Wrench
TTH0369	A20Q SVUCR/L 11	♦	20	25	18.3	180	13	-	-	-	TXS2506	TXW08
TTH0370	A25R SVUCR/L 16	♦	25	32	23	200	19	HSV16PA	HSAV35	HA3.5	TXS3514	TXW15
TTH0364	S16P SVUCR/L 11	✘	16	20	14.8	170	12.5	-	-	-	TXS2506	TXW08
TTH0365	S20R SVUCR/L 11	✘	20	25	18.3	200	13					
TTH0366	S25S SVUCR/L 16	✘	25	32	23	250	19					
TTH0367	S32T SVUCR/L 16	✘	32	40	30	300	22					
TTH0368	S40U SVUCR/L 16	✘	40	50	37.5	350	27	HSV16PA	HSAV35	HA3.5	TXS3514	TXW15

To order left hand add L to EDP code. Example: A20Q SVUCL 11 = TTH0369L

- SVXBR/L

For VB.. positive inserts

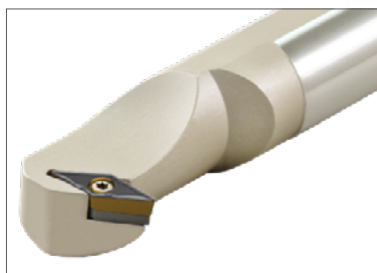

Right hand holder shown

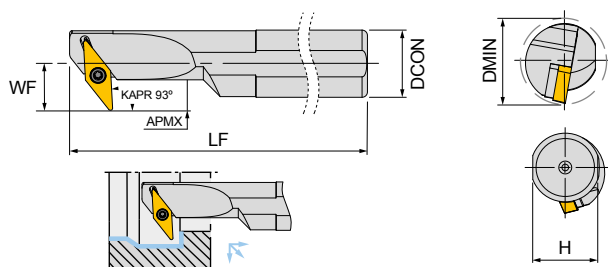

Insert	
	VBGT 1103.. VBMT 1103..
	VBMT 1604..

EDP Code	Description	♦	DCON	DMIN	H	LF	WF	APMX	Shim	Shim Screw	Shim Key	Insert Screw	Wrench
TTH0540	S16P SVXBR/L 11	✘	16	20	14.8	170	12.5	7.2	-	-	-	TXS2506	TXW08
TTH0541	S20R SVXBR/L 11	✘	20	25	18.3	200	13	5.7					
TTH0542	S25S SVXBR/L 16	✘	25	32	23	250	19	10.2	HSV16PA	HSAV35	HA3.5	TXS3514	TXW15
TTH0543	S32T SVXBR/L 16	✘	32	40	30	300	22	11.7					

To order left hand add L to EDP code. Example: S16P SVXBL 11 = TTH0540L



ANTI-VIBRATION TOOLS

QuietBore

AVB.

For all AVH heads

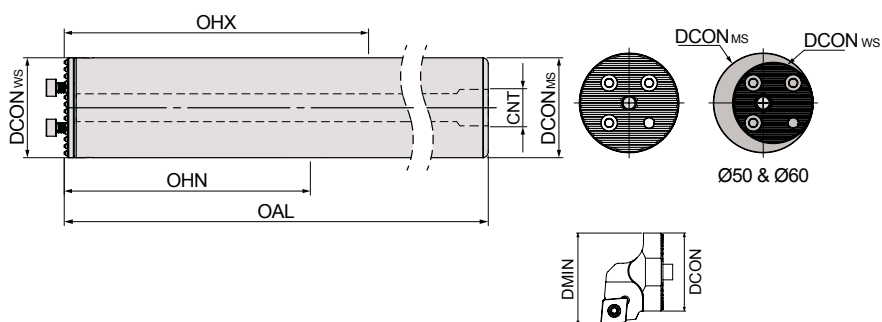
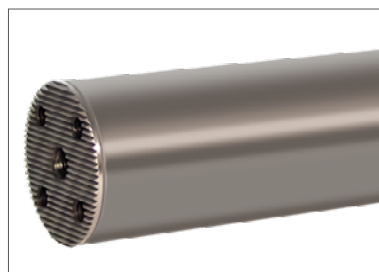

EDP Code	Description	DCON _{ms}	DCON _{ws}	OAL	OHN	OHX	CNT	DCON	DMIN	Screw	Key
AVT0143	AVB.161567D	16	16	156	55	92	G1/8	16	20	M3X10IMB	HA2.5
AVT0144	AVB.1620410D	16	16	204	96	140	G1/8	16	20	M3X10IMB	HA2.5
AVT0145	AVB.202007D	20	20	200	70	120	G1/4	20	25	M3.5X10IMB	HA2.5
AVT0146	AVB.2026010D	20	20	260	120	180	G1/4	20	25	M3.5X10IMB	HA2.5
AVT0147	AVB.252557D	25	25	255	88	158	G1/4	25	32	M4X12IMB	HA3
AVT0148	AVB.2533010D	25	25	330	155	230	G1/4	25	32	M4X12IMB	HA3
AVT0149	AVB.323207D	32	32	320	100	192	G3/8	32	40	M5X16IMB	HA4
AVT0150	AVB.3241610D	32	32	416	192	288	G3/8	32	40	M5X16IMB	HA4
AVT0151	AVB.404087D	40	40	408	128	248	G1/2	40	50	M6X16IMB	HA5
AVT0152	AVB.4052810D	40	40	528	248	368	G1/2	40	50	M6X16IMB	HA5
AVT0153	AVB.505197D	50	40	519	168	318	G1/2	40	63	M6X16IMB	HA5
AVT0154	AVB.5066910D	50	40	669	318	468	G1/2	40	63	M6X16IMB	HA5
AVT0155	AVB.606287D	60	40	628	208	388	G3/4	40	80	M6X16IMB	HA5
AVT0156	AVB.6080810D	60	40	808	388	568	G3/4	40	80	M6X16IMB	HA5

For assembly and operating instructions see page 55

AVO.

Precision orientation attachment

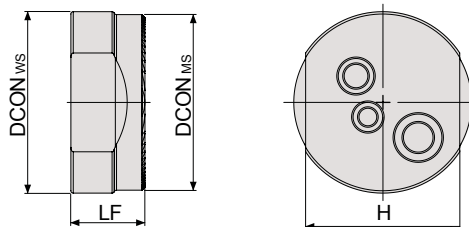

EDP Code	Description	DCON _{ms}	DCON _{ws}	LF	H	TO SUIT BAR TYPE
AVT0175	AVO.16-25	28	25	15	22	AVB.16 - AVB.25
AVT0176	AVO.32-60	53	40	20	35	AVB.32 - AVB.60



ANTI-VIBRATION TOOLS

QuietBore

AVH..TCLNR/L For CN.. negative inserts



Right hand holder shown

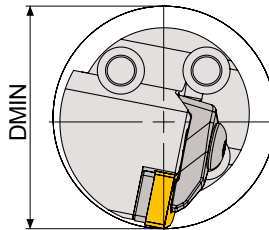
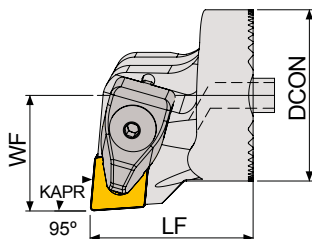

Insert	
	CNGG 1204..
	CNMA 1204..
	CNMG 1204..
	CNMM 1204..

EDP Code	Description		DCON	LF	WF	DMIN	Clamp	Clamp Screw	Shim	Shim Screw	Spring	Washer	Key
AVT0157	AVH.A32 TCLNR 12		32	32	22	40	TTBP-2.1	HMBV6M.1	HPC12NA	HBi5	HCY6.1	TTBR-2	HA3
AVT0158	AVH.A40 TCLNR 12		40	38	27	50							

To order left hand add L to EDP code. Example: AVH.A32 TCLNL 12 = AVT0157L

AVH..TDUNR/L For DN.. negative inserts



Right hand holder shown

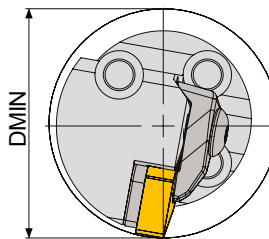
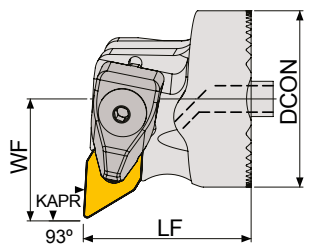

Insert	
	DNGG 1506..
	DNMA 1506..
	DNMG 1104.. DNMG 1504.. DNMG 1506..
	DNMM 1506..

EDP Code	Description		DCON	LF	WF	DMIN	Clamp	Clamp Screw	Shim	Shim Screw	Spring	Washer	Key
AVT0159	AVH.A32 TDUNR 11		32	32	22	40	TTBP-1.1	HMBV5M.1	HSD11PA	HBi5.2	HCY6.1	TTBR-2	HA3
AVT0160	AVH.A40 TDUNR 15		40	38	27	50	TTBP-2.1	HMBV6M.1	HPD15NA	HBi5	HCY6.1	TTBR-2	HA3

To order left hand add L to EDP code. Example: AVH.A32 TDUNL 11 = AVT0159L

For DNMG 1504 inserts, order additional shim HPD15XA



ANTI-VIBRATION TOOLS

QuietBore

AVH..SCLCR/L

For CC.. positive inserts



Right hand holder shown

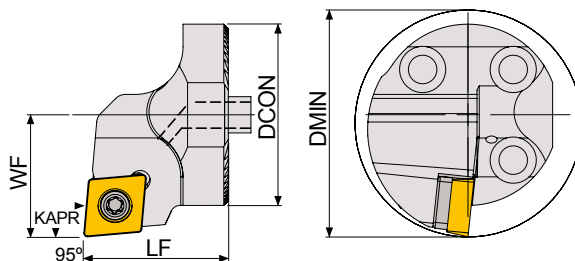

Insert	
	CCGT 0602.. CCGT 09T3.. CCGT 1204..
	CCMT 0602.. CCMT 09T3.. CCMT 1204..

EDP Code	Description	⚡	DCON	LF	WF	DMIN	Shim	Shim Screw	Shim Key	Insert Screw	Wrench
AVT0161	AVH.A16 SCLCR 06	⚡	16	20	11	20	-	-	-	TXS2506	TXW08
AVT0162	AVH.A20 SCLCR 09	⚡	20	20	13	25	-	-	-	TXS3511	TXW15
AVT0163	AVH.A25 SCLCR 09	⚡	25	23	17	32	HSC09PA	HSAV35.1	HA3.5	TXS3512.1	TXW15
AVT0164	AVH.A32 SCLCR 09	⚡	32	32	22	40				TXS3514	
AVT0165	AVH.A40 SCLCR 12	⚡	40	32	27	50	HSC12PA	HSAV45	HA4.5	TXS4516	TXW20F

To order left hand add L to EDP code. Example: AVH.A16 SCLCL 06 = AVT0161L

AVH..SDUCR/L

For DC.. positive inserts



Right hand holder shown

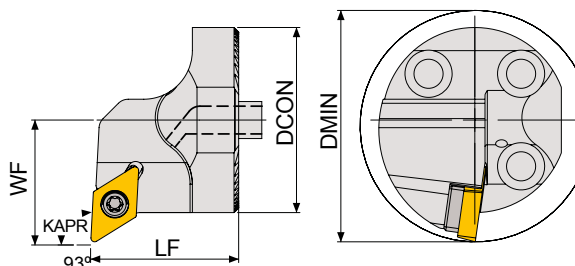

Insert	
	DCGT 0702.. DCGT 11T3..
	DCMT 0702.. DCMT 11T3..

EDP Code	Description	⚡	DCON	LF	WF	DMIN	Shim	Shim Screw	Shim Key	Insert Screw	Wrench
AVT0166	AVH.A16 SDUCR 07	⚡	16	20	11	20	-	-	-	TXS2506	TXW08
AVT0167	AVH.A20 SDUCR 11	⚡	20	20	13	25	-	-	-	TXS3511	TXW15
AVT0168	AVH.A25 SDUCR 11	⚡	25	23	17	32	HSD11PA	HSAV35.1	HA3.5	TXS3512.1	TXW15
AVT0169	AVH.A32 SDUCR 11	⚡	32	32	22	40	HSD11PA	HSAV35	HA3.5	TXS3514	TXW15
AVT0170	AVH.A40 SDUCR 11	⚡	40	32	27	50					

To order left hand add L to EDP code. Example: AVH.A16 SDUCL 07 = AVT0166L



ANTI-VIBRATION TOOLS

QuietBore

AVH..SVUCR/L

For VC.. positive inserts

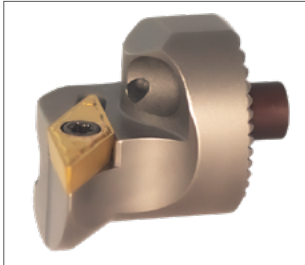

Right hand holder shown

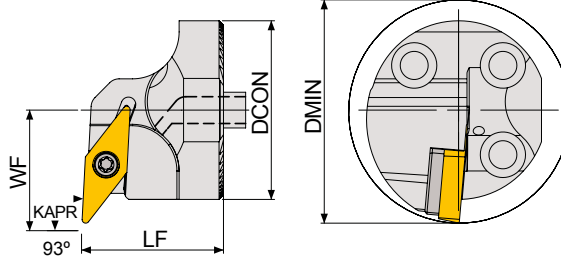

Insert	
	VCMT 1103.. VCMT 1604..
	VCGT 1103.. VCGT 1604..

EDP Code	Description		DCON	LF	WF	DMIN	Shim	Shim Screw	Shim Key	Insert Screw	Wrench
AVT0171	AVH.A20 SVUCR 11		20	20	15	27	-	-	-	TXS2506	TXW08
AVT0172	AVH.A25 SVUCR 11		25	23	17	32	-	-	-	TXS2506	TXW08
AVT0173	AVH.A32 SVUCR 16		32	32	22	40	HSV16PA	HSAV35	HA3.5	TXS3514	TXW15
AVT0174	AVH.A40 SVUCR 16		40	32	27	50					

To order left hand add L to EDP code. Example: AVH.A20 SVUCL 11 = AVT0171L



ANTI-VIBRATION TOOLS

QuietBore

Assembly

The shank and the cartridge mounting surfaces, A and B, in addition to the inside of the holder must be cleaned before assembly.

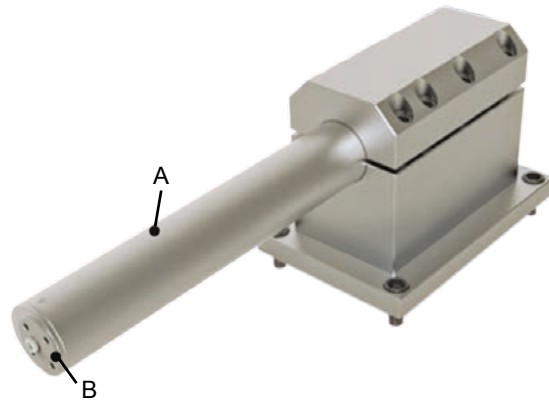

Mounting

If the available clamping method is less than $4xD$, please ensure that clamp Type C is used. Do not clamp only on the top of the bar. High pressure internal coolant is recommended for all deep bores.

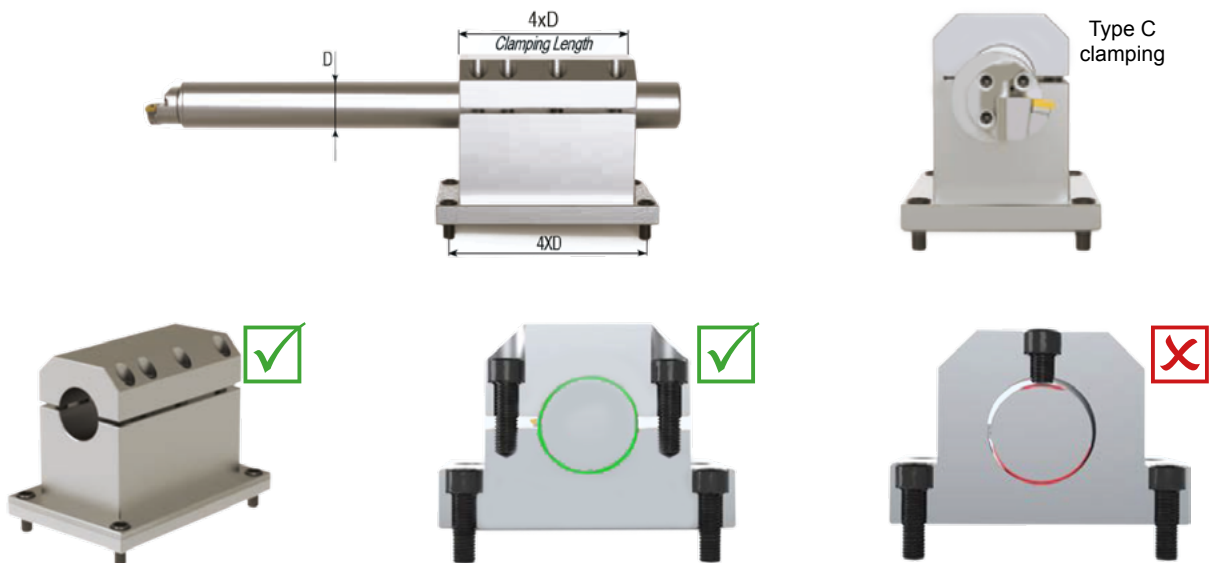

Bar positioning

When mounting the bar for the first time, please use the AVO precision orientation attachment to achieve correct positioning. The orientation must be within 0.01mm tolerance on the X axis direction.





COOLANT CONNECTION SPARES

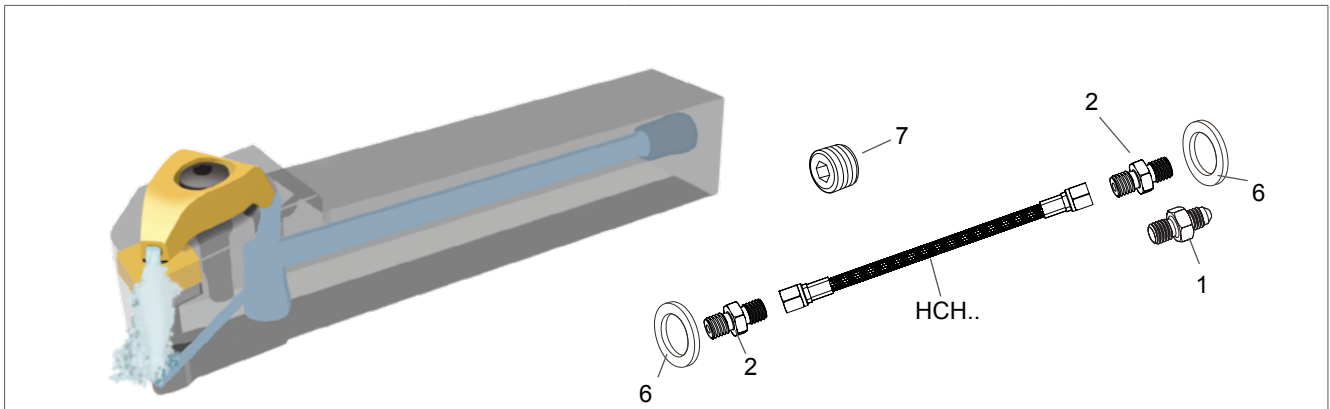

Three types of coolant hose are available to suit all types of internally cooled lathes. Before use, care should be taken to ensure that all unused connections are closed off using the blanking plug and that the seal is secure. Coolant hoses are designed for use in the pressure range of 10 bar to 275 bar.

Item	EDP Code	Description	Image	Item	EDP Code	Description	Image
1	HCF01	DOUBLE CONNECTOR M10		6	HCG01	COPPER GASKET	
2	HCF02	DOUBLE CONNECTOR G1/8		7	HXS1855	BLANKING PLUG G1/8	
3	HCF03	ANGLE CONNECTOR G1/8		8	HCH01	CONNECTION HOSE TYPE 1	
4	HCF04	ANGLE CONNECTOR M10		9	HCH02	CONNECTION HOSE TYPE 2	
5	HCF05	G1/4-G1/8 REDUCER		10	HCH03	CONNECTION HOSE TYPE 3	



CODE	PAGE	CODE	PAGE	CODE	PAGE
A-PCLNR/L	38	PCBNR/L	15	SDJCR/L-S	33
A-PDUNR/L	39	PCLNR/L	15	SDNCN	23
A-PDXNR/L	39	PDJNR/L	16	SRDCN	25
A-PSKNR/L	40	PDNNN	16	SRGCR/L	24
A-PTUNR/L	41	PSSNR/L	17	SSDCN	26
A-PWLNR/L	42	PTJNR/L	17	STFCR/L	27
A-SCLCR/L	43	PWLNR/L	18	STGCR/L	27
A-SDUCR/L	44	S-PCLNR/L	38	STGCR/L-S	34
A-SDXCR/L	45	S-PDUNR/L	39	SVACR/L-S	35
A-SRGCR/L	46	S-PDXNR/L	39	SVJBR/L	28
A-STUCR/L	47	S-PSKNR/L	40	SVJCR/L	29
A-SVUCR/L	48	S-PTUNR/L	41	SVJCR/L-EC	37
AVB	49	S-PWLNR/L	42	SVJCR/L-S	36
AVH.SCLCR/L	51	S-SCLCR/L	43	SVVCN	29
AVH.SDUCR/L	51	S-SDQCR/L	45	TCBNR/L	4
AVH.SVUCR/L	52	S-SDUCR/L	44	TCKNR/L	5
AVH.TCLNR/L	50	S-SDXCR/L	45	TCLNR/L	6
AVH.TDUNR/L	50	S-SRGCR/L	46	TCMNN	7
AVO	49	S-STUCR/L	47	TCZNN	7
CKJNR/L	21	S-SVUCR/L	48	TDJNR/L	8
E-SCLCR/L	43	S-SVXBR/L	48	TDNNN	9
E-SDUCR/L	44	SCACR/L-S	30	TSSNR/L	10
MSTB	37	SCLCR/L	22	TTJNR/L	11
MTENN	19	SCLCR/L-S	31	TVJNR/L	12
MTJNR/L	19	SDACR/L-S	32	TVVNN	13
MWLNRL	20	SDJCR/L	23	TWLNRL	14
MWMNN	20	SDJCR/L-EC	37		