



Clarkson

Abverkauf 2020

Werkzeugaufnahmen + Zubehör
+ HM-Schaftfäser

Nur solange Vorrat

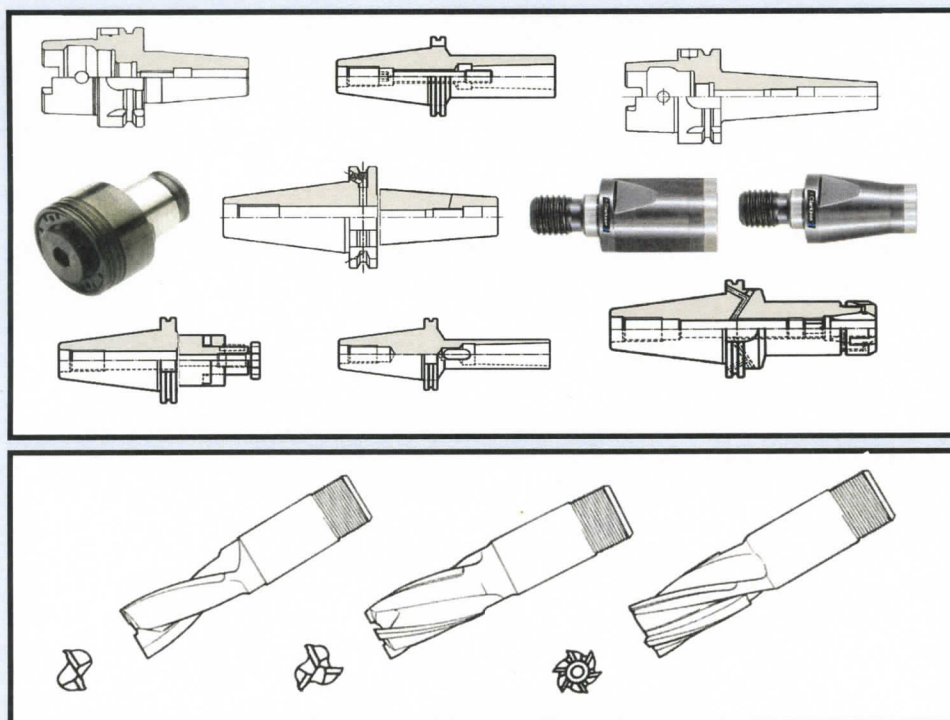

Mindestauftragswert 100,--€

Frachtfrei ab einem Auftragswert
von 250,--€

Clarkson GmbH
Heinrich-Hertz Str.52
40699 Erkrath
Tel.:0211/72003-0 Fax: 0211/72003-33
Email: info@clarkson.de
Web: www.clarkson.de

Schrumpffutter

PYROquart

Code Nr	Stck	Kegel	Ød	Ød1	ØD	A	€/Stück
HSK A							
273.A40.006.058	3	HSK40A	6	19	25	58	60,00 €
273.A40.008.063	3	HSK40A	8	21	28	63	60,00 €
270.A63.006.226	1	HSK63A	6	12	50	226	157,00 €
273.A10.014.090	2	HSK100A	14	30	47	90	70,00 €
HSK E							
273.E25.003.035	2	HSK25E	3	10	20	35	60,00 €
273.E25.004.035	1	HSK25E	4	12	20	35	60,00 €
273.E25.006.035	1	HSK25E	6	19	20	35	60,00 €
273.E32.003.100	1	HSK32E	3	10	14	100	70,00 €
273.E32.008.045	5	HSK32E	8	21	23	45	60,00 €
273.E32.010.045	1	HSK32E	10	23	25	45	60,00 €
273.E40.005.100	2	HSK40E	5	14	33	100	70,00 €
273.E40.010.100	2	HSK40E	10	23	33	100	70,00 €
273.E40.012.100	2	HSK40E	12	25	33	100	70,00 €
273.E40.016.100	2	HSK40E	16	29	33	100	70,00 €
273.E50.004.055	1	HSK50E	4	12	23	55	60,00 €
273.E50.006.170	1	HSK50E	6	12	32	170	80,00 €
273.E50.010.060	1	HSK50E	10	26	35	60	60,00 €
273.E50.012.060	1	HSK50E	12	28	41	60	60,00 €
273.E50.016.120	2	HSK50E	16	29	42	120	70,00 €
273.E50.020.120	3	HSK50E	20	33	42	120	70,00 €
HSK F							
273.F63.010.070	2	HSK63F	10	24	28	70	70,00 €
SK DIN69871							
273.230.016.060	5	SK30/AD	16	32	38	60	50,00 €
273.340.008.120	1	SK40/ADB	8	24	42	120	50,00 €
273.250.016.080	1	SK50/AD	16	32	55	80	80,00 €
273.350.025.080	1	SK50/ADB	25	41	64	80	80,00 €

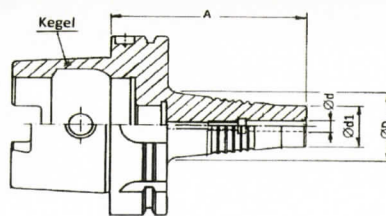

HSK-A
Typ: 273

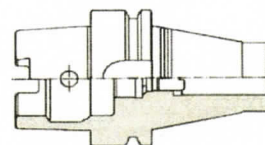

HSK-A
Typ: 270

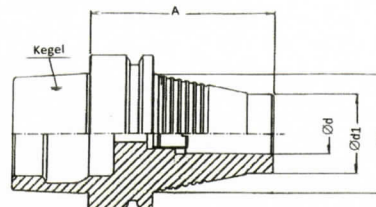

HSK-E
Typ: 273

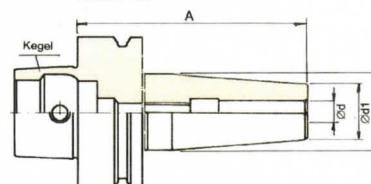

HSK-F
TYP: 271

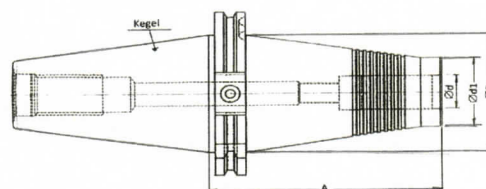

DIN69871
Typ: 273

DIN 69882-8

Code Nr	Stck	Kegel	Ød	Ød1	ØD	A	€/Stück
HSK A							
280.A63.006.160	1	HSK63A	6	21	27	160	80,00 €
SK DIN69871							
271.350.018.080	2	SK50/ADB	18	33	42	80	80,00 €
280.350.008.097	3	SK50/ADB	8	20	30	97,1	206,00 €
MAS/BT							
271.850.012.080	2	BT50/ADB	12	28	34	80	80,00 €
271.850.016.080	2	BT50/ADB	16	32	34	80	80,00 €

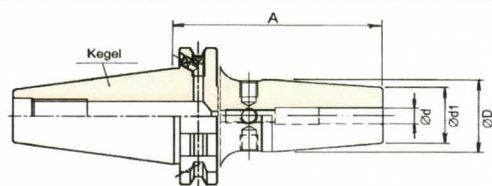

DIN69871
Typ: 280

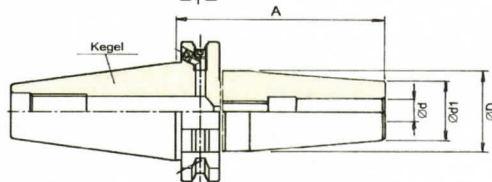

DIN69871
TYP: 271

Slim line

Code Nr	Stck	Kegel	Ød	Ød1	ØD	A	€/Stück
HSK A							
282.A63.003.100	3	HSK63A	3	9	11,5	100	92,00 €
285.A63.003.126	9	HSK63A	3	11	22	126	141,00 €
272.A10.003.200	1	HSK100A	3	6	32	200	156,00 €
272.A10.005.200	1	HSK100A	5	10	32	200	156,00 €
282.A10.012.137	3	HSK100A	12	20	34	137	80,00 €

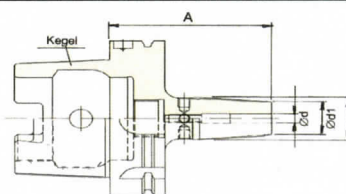

HSK-A
Typ: 282

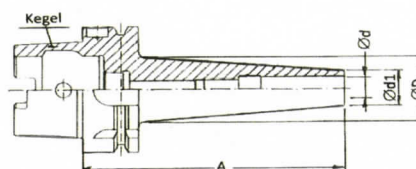

HSK-A
Typ: 272

Schrumpffverlängerungen

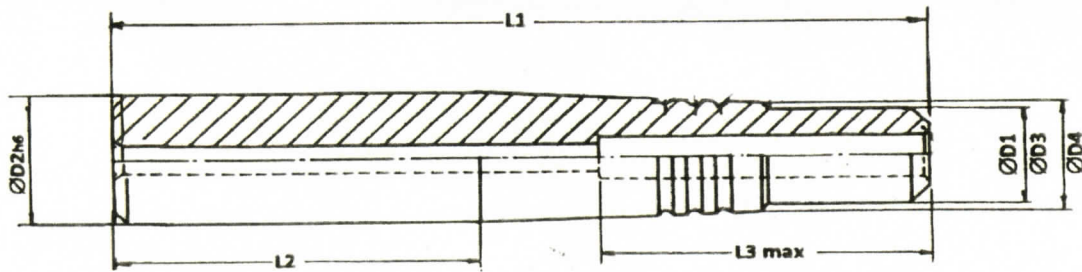

Code Nr	Stck	ØD1	ØD2	L1	ØD3	ØD4	L2	L3 max	€/Stück
0470163586	5	3	12	100	6	7	40	~	60,00 €
0470163587	3	3	12	150	6	7	40	~	60,00 €
0470163584	4	4	12	100	8	9	40	~	157,00 €
0470163585	2	4	12	150	8	9	40	~	70,00 €
0470163582	3	5	12	100	9	10	40	~	60,00 €
0470163583	1	5	12	150	9	10	40	~	60,00 €
0470163580	2	6	12	100	10	11	40	32	60,00 €
0470163581	2	6	12	150	10	11	40	32	70,00 €
0470169012/06150ES	2	6	12	150	9	~	120	~	60,00 €
0470163572	6	8	16	100	13	14	45	37	60,00 €
0470163573	6	8	16	150	13	14	45	37	70,00 €
0470163570	6	10	16	100	16	~	45	37	70,00 €
0470163571	5	10	16	150	16	~	45	37	70,00 €
0470163562	8	12	25	100	19	20	50	37	70,00 €
0470163563	6	12	25	150	19	20	50	37	60,00 €
0470163561	2	16	25	150	24	25	50	40	80,00 €

Reduzierhülsen

HSK A

Code Nr	Stck	Kegel	MK	d2	l	l1	€/Stück
220.A63.004.000	1	HSK63A	MK4	48	161	135	40,00 €
221.A63.003.206	1	HSK63A	MK3	40	206	180	50,00 €

SK DIN2080

Code Nr	Stck	Kegel	MK	d2	l	l1	€/Stück
220.140.003.000	1	SK40	MK3	40	65	53	25,00 €
220.050.002.000	3	SK50	MK2	32	60	45	25,00 €
220.050.003.000	2	SK50	MK3	40	65	50	25,00 €
225.050.004.160	1	SK50	MK4	48	70	55	25,00 €

SK DIN69871

Code Nr	Stck	Kegel	MK	d2	l	l1	€/Stück
221.240.002.050	2	SK40	MK2	32	50	31	25,00 €
221.240.003.070	2	SK40	MK3	40	70	51	25,00 €
224.240.004.110	2	SK40	MK4	48	110	91	25,00 €

SK MAS/BT

Code Nr	Stck	Kegel	MK	d2	l	l1	€/Stück
221.840.004.000	1	BT40	MK4	48	70	43	25,00 €
221.850.002.000	1	BT50	MK2	32	60	22	25,00 €

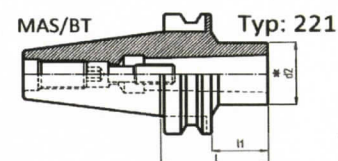
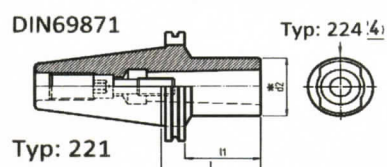
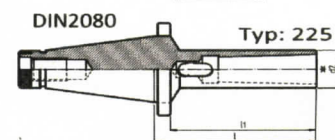
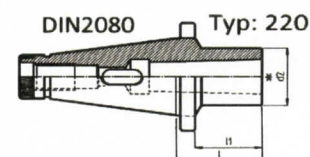
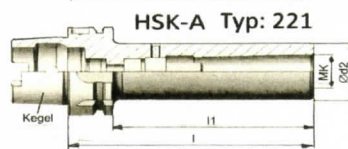
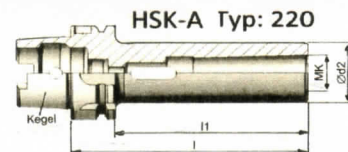

Adapter für Einschraubfräser

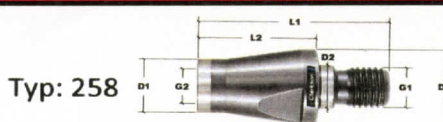
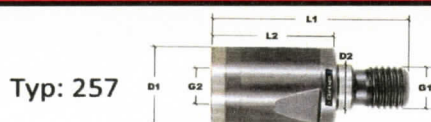

Code Nr	Stck	G1	G2	D1	D2	D3	L1	L2	€/Stück
257.M10.M10.035	4	M10	M10	17,8	10,5	~	55	35	20,00 €
258.M08.M06.025	1	M8	M6	9,8	8,5	12,8	43	25	20,00 €
258.M12.M10.035	2	M12	M10	17,8	12,5	20,8	57	35	20,00 €

Einschraubaufnahmen

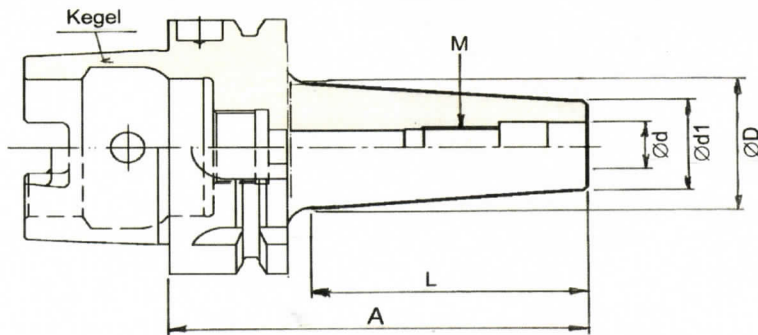

HSK-A
Typ: 254 Typ: 264

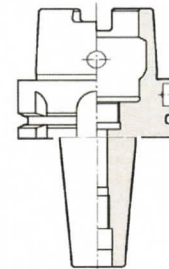

HSK-E
Typ: 254

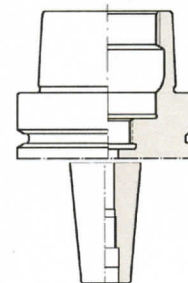

DIN69871
Typ: 254

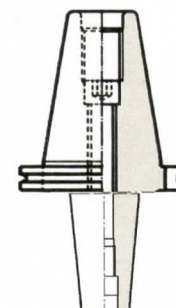

MK DIN228A
Typ: 254

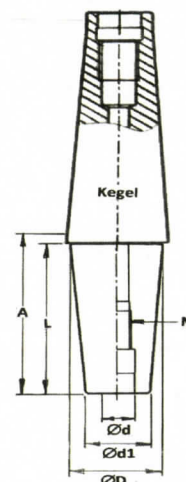

Code Nr	Stck	Kegel	M	Ød	Ød1	ØD	A	L	€/Stück
HSK A									
254.A50.M08.059	3	HSK50A	M8	8,5	13	18	59	25	40,00 €
254.A50.M10.059	3	HSK50A	M10	10,5	18	23	59	25	40,00 €
254.A50.M10.084	2	HSK50A	M10	10,5	18	25	84	50	43,00 €
254.A50.M12.109	1	HSK50A	M12	12,5	21	25	109	75	49,00 €
264.A63.M08.059	5	HSK63A	M8	8,5	12,8	14,5	59	25	58,00 €
264.A63.M08.109	5	HSK63A	M8	8,5	12,8	23	109	75	63,00 €
264.A63.M10.059	5	HSK63A	M10	10,5	17,8	19,5	59	25	58,00 €
264.A63.M10.109	5	HSK63A	M10	10,5	17,8	28	109	75	63,00 €
264.A63.M12.059	5	HSK63A	M12	12,5	20,8	23,5	59	25	58,00 €
264.A63.M12.109	5	HSK63A	M12	12,5	20,8	31	109	75	63,00 €
264.A63.M12.184	5	HSK63A	M12	12,5	23	50	184	150	70,00 €
264.A63.M16.059	5	HSK63A	M16	17,0	28,8	29,5	59	25	58,00 €
264.A63.M16.109	5	HSK63A	M16	17,0	28,8	37	109	75	63,00 €
254.A80.M08.109	4	HSK80A	M8	8,5	12,8	23	109	75	92,00 €
254.A80.M12.109	1	HSK80A	M12	12,5	20,8	31	109	75	86,00 €
254.A10.M10.054	3	HSK100A	M10	10,5	18	23	54	15	83,00 €
254.A10.M12.054	2	HSK100A	M12	12,5	21	26	54	18	83,00 €
HSK E									
254.E40.M08.053	2	HSK40E	M8	8,5	13,5	17,5	53	24	70,00 €
254.E50.M08.051	3	HSK50E	M8	8,5	13,8	16,5	51	22	40,00 €
254.E50.M08.101	1	HSK50E	M8	8,5	13	24	101	70	43,00 €
254.E50.M12.126	2	HSK50E	M12	12,5	21	33	126	95	49,00 €
SK DIN69871									
254.240.M08.078	1	SK40/AD	M8	8,5	13	23	78	54	40,00 €
254.340.M10.069	2	SK40/ADB	M10	10,5	17,8	23	69	47	40,00 €
254.340.M12.069	2	SK40/ADB	M12	12,5	21	24	69	47	40,00 €
254.250.M08.058	1	SK50/AD	M8	8,5	13	16	58	34	44,00 €
254.250.M10.078	1	SK50/AD	M10	10,5	18	25	78	50	50,00 €
254.250.M10.098	1	SK50/AD	M10	10,5	18	28	98	75	50,00 €
254.250.M12.098	1	SK50/AD	M12	12,5	21	33	98	75	50,00 €
254.250.M16.038	1	SK50/AD	M16	17,0	29	30	38	14	44,00 €
254.250.M16.078	1	SK50/AD	M16	17,0	29	35	78	50	50,00 €
254.350.M16.058	1	SK50/ADB	M16	17,0	29	35	58	34	40,00 €
254.350.M16.076	1	SK50/ADB	M16	17,0	29	32	76	50	40,00 €
MK DIN228 A									
254.MK1.M06.020	2	MK1/M6	M6	6,5	10	12	23	19,5	17,00 €
254.MK1.M06.040	1	MK1/M6	M6	6,5	10	12	43	39,5	17,00 €
254.MK3.M12.075	1	MK3/M12	M12	12,5	20,5	24	72	67	18,00 €
254.MK4.M12.120	2	MK4/M16	M12	12,5	21	31	120	113,5	30,00 €
254.MK5.M16.140	1	MK5/M20	M16	17,0	29	29	140	133,5	60,00 €
254.MK5.M16.180	1	MK5/M20	M16	17,0	29	29	180	173,5	63,00 €

Zangenspannfutter

OZ DIN6388

Code Nr	Stck	Kegel	Ød1	Ød2	l1	l3	l	€/Stück
DIN 2080								
255.140.025.016	5	SK40	1,5-16	43	44	~	56	30,00 €
255.140.035.025	3	SK40	2-25	60	44	~	56	32,00 €
255.050.035.025	6	SK50	2-25	60	55	~	70	25,00 €
255.050.044.032	2	SK50	3,5-32	72	55	~	70	27,00 €

DIN 69871

255.245.035.025	2	SK45	2-25	60	51	~	70	30,00 €
255.245.044.032	1	SK45	3,5-32	72	51	~	70	32,00 €
255.250.035.025	3	SK50	2-25	60	51	~	70	25,00 €
255.250.044.032	2	SK50	3,5-32	72	61	~	80	27,00 €

MAS BT

255.840.025.016	2	BT40	1,5-16	43	43	~	70	30,00 €
255.850.035.025	2	BT50	1,5-16	60	47	~	85	30,00 €
255.850.044.032	2	BT50	3,5-32	72	52	~	90	32,00 €

ER' DIN6499

DIN 69871

244.240.032.020	5	SK40	1,5-20	50	106	~	125	20,00 €
-----------------	---	------	--------	----	-----	---	-----	---------

Weldon-Aufnahmen

DIN 2080

269.140.016.000	2	SK40	16	48	51	~	63	20,00 €
269.050.010.000	4	SK50	10	35	48	~	63	25,00 €
269.050.012.000	5	SK50	12	42	48	~	63	25,00 €

SK DIN69871

269.350.025.035	1	SK50ADB	25	65	61	~	35	25,00 €
-----------------	---	---------	----	----	----	---	----	---------

MAS BT

269.850.012.000	1	BT50	12	42	37	~	75	20,00 €
269.850.020.000	1	BT50	20	52	67	~	105	20,00 €
269.850.025.000	1	BT50	25	65	67	~	105	20,00 €
269.850.032.105	1	BT50	32	72	67	~	105	20,00 €
269.850.040.000	2	BT50	40	80	77	~	115	20,00 €

NC-Bohrfutter

Code Nr	Stck	Kegel	Ød1	D	l1	l3	A	€/Stück
---------	------	-------	-----	---	----	----	---	---------

SK DIN69871

342.240.058.070	2	SK40AD	0,5-8	36	~	~	70	80,00 €
342.240.001.013	1	SK40AD	1,0-13	50	~	~	81	60,00 €

Kombi-Aufsteckdorn

Code Nr	Stck	Kegel	Ød1	Ød2	l1	l3	l	€/Stück
---------	------	-------	-----	-----	----	----	---	---------

MAS/BT

238.840.040.027	1	BT40	40	70	33	~	60	25,00 €
238.850.022.019	2	BT50	22	40	32	~	70	25,00 €

DIN 2080

238.050.050.030	1	SK50	50	90	40	~	55,2	30,00 €
-----------------	---	------	----	----	----	---	------	---------

Aufsteckdorn für Werkzeuge mit Längsnut

DIN69871

307.250.032.060	1	SK50	32	50	31	60	50	30,00 €
307.250.040.060	1	SK50	40	60	32	60	50	35,00 €

Bohrfutter Aufnahme

Code Nr	Stck	Kegel	D	L	A	€/Stück
---------	------	-------	---	---	---	---------

DIN 2080

211.050.018.000	3	SK50	B18	32	25		30,00 €
-----------------	---	------	-----	----	----	--	---------

DIN69871

211.250.018.000	3	SK50	B18	32	25		30,00 €
-----------------	---	------	-----	----	----	--	---------

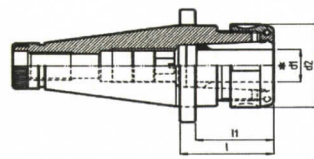

DIN2080
Typ: 255

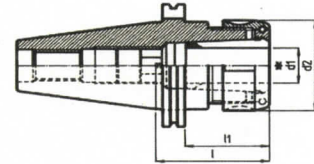

DIN69871
Typ: 255

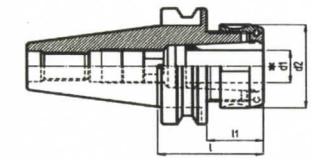

MAS/BT
Typ: 255

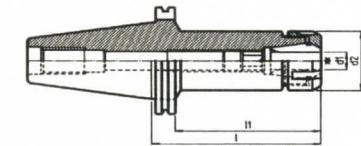

DIN69871
Typ: 244

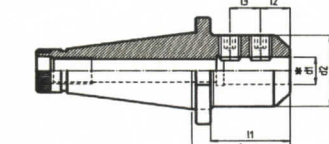

DIN2080
Typ: 269

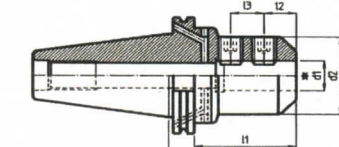

DIN69871
Typ: 269

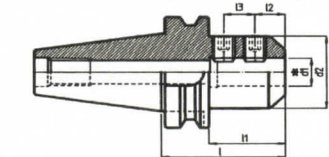

MAS/BT
Typ: 269

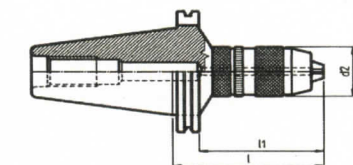

DIN69871
Typ: 342

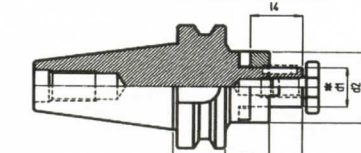

MAS/BT
Typ: 238

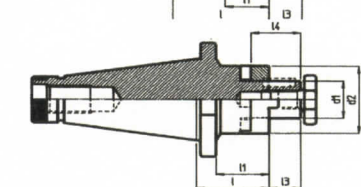

DIN2080
Typ: 238

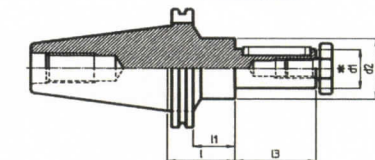

DIN69871
Typ: 307

DIN2080

DIN69871

Typ: 211

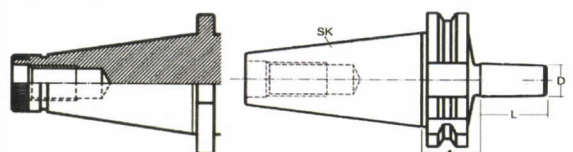

Halter für WP-Bohrer

DIN 69871

Code Nr	Stck	Kegel	Ød1	Ød2	l1	l	l3	€/Stück
227.340.025.070	1	SK40ADB	25	45	50	70	~	20,00 €

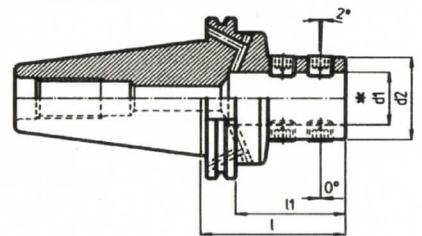

Stellhülseaufnahme

SK DIN69871

Code Nr	Stck	Kegel	Ød1	Ød2	l1	l	l3	€/Stück
320.240.028.000	1	SK40AD	28	55	51	70	~	25,00 €

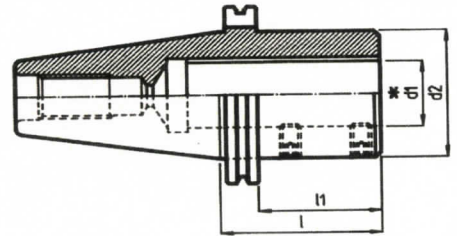

Messekopfaufnahme

SK DIN69871

Code Nr	Stck	Kegel	Ød1	Ød2	l1	l	l3	€/Stück
239.250.027.021IK	1	SK50ADB	27	58	37	56	21	20,00 €

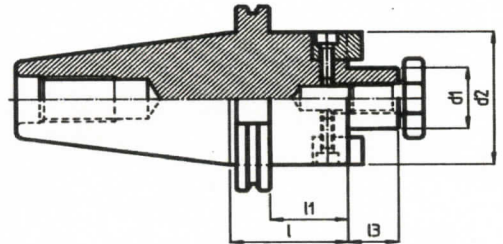

HSK A

Code Nr	Stck	Kegel	Ød1	Ød2	l1	l	l3	€/Stück
239.A63.027.055	2	HSK63	27	58	29	55	21	50,00 €
239.A63.032.060	3	HSK63	32	78	34	60	24	55,00 €

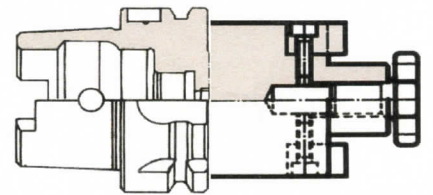

Aufsteckdorn

SK DIN69871

Code Nr	Stck	Kegel	Ød1	Ød2	l1	l	l3	€/Stück
245.250.040.120	1	SK50	40	70	100	120	27	25,00 €

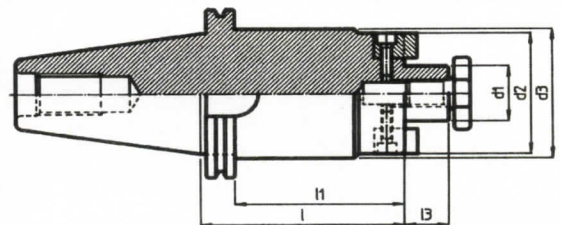

Hydro-Dehnspannfutter

DIN69871

Code Nr	Stck	Kegel	Ød	Ød1	Ød2	l1	L	€/Stück
260.350.012.080	1	SK50ADB	12	30	32	60	80	100,00 €

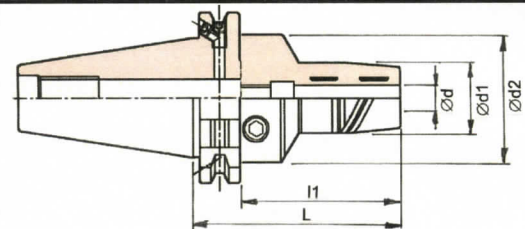

AUTOLOCK-Spannfutter

DIN69871

Code Nr	Stck	Kegel	Ød	Ød1	l1	L	l3	€/Stück
8M159Y	1	SK50	25/32	76	85	105	~	75,00 €

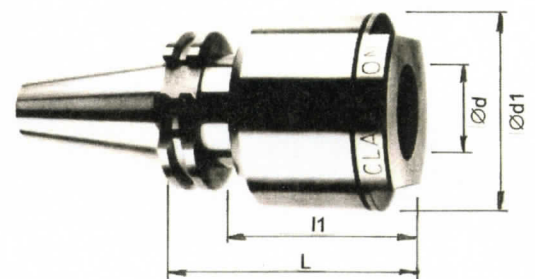

VHM-Einschraub-Verlängerung

Code Nr	Stck	G1	D2	D1	L2	L1	€/Stück
512.200.225.024	2	M12	25	24	101	200	200,00 €

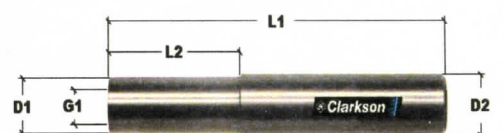

HM-Schaftfräser

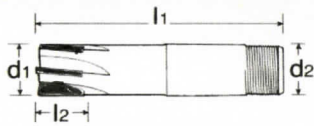

Code Nr	Stück	Ød1 / js14	Ød2 / h6	l2	l1	Z	SP	HM	€/Stück
861M24	1	12	16	25	85	2	25°	K10	17,00 €
861M28	10	14	16	25	85	2	25°	K10	20,00 €
861M32	14	16	16	32	90	2	25°	K10	21,00 €
861M64	1	32	32	50	125	4	25°	K10	48,00 €
862M28	3	14	16	25	85	2	25°	P25	20,00 €
862M32	4	16	16	32	90	2	25°	P25	21,00 €
862M36	20	18	16	32	90	3	25°	P25	22,50 €
862M40	3	20	16	40	104	3	25°	P25	22,50 €
862M44	8	22	25	50	125	3	25°	P25	27,00 €
862M50	6	25	25	50	125	4	25°	P25	37,00 €
862M56	4	28	25	50	125	4	25°	P25	40,00 €
862M64	5	32	32	50	125	4	25°	P25	40,00 €

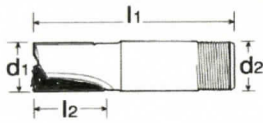

Code Nr	Stück	Ød1 / e8	Ød2 / h6	l2	l1	Z	SP	HM	€/Stück
863M28	13	14	16	32	76	2	25°	K10	17,00 €
863M32	13	16	16	25	79	2	25°	K10	20,00 €
863M50	2	25	25	32	103	2	25°	K10	21,00 €
863M64	7	32	32	40	113	2	25°	K10	48,00 €
864M28	6	14	16	32	76	2	25°	P25	20,00 €
864M32	7	16	16	25	79	2	25°	P25	21,00 €
864M40	1	20	16	25	86	2	25°	P25	22,50 €
864M50	8	25	25	32	103	2	25°	P25	22,50 €
864M64	7	32	32	40	113	2	25°	P25	27,00 €

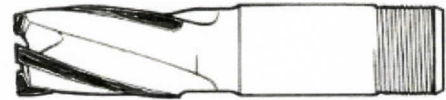
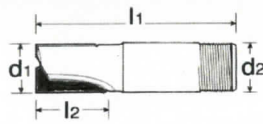

Code Nr	Stück	Ød1 / e8	Ød2 / h6	l2	l1	Z / Typ	SP	HM	€/Stück
865M20	2	10	10	12	63	3 / A	25°	K10	10,00 €
865M40	3	20	16	25	86	3 / B	25°	K10	12,00 €
865M44	1	22	25	50	125	3 / A	25°	K10	31,00 €
866M36	3	18	16	33	90	3 / A	25°	P25	25,00 €
866M40	3	20	16	25	86	3 / B	25°	P25	31,00 €
866M44	3	22	25	50	125	3 / A	25°	P25	38,00 €
866M50	1	25	25	32	103	3 / B	25°	P25	46,00 €
866M64	1	32	32	40	113	3 / B	25°	P25	50,00 €

Clarkson GmbH



Wendepplattenwerkzeuge

06/2020

Clarkson GmbH



Rotorfräser

09/2019

Clarkson GmbH



DIN69880
(VDI 3425)

09/2019

Clarkson EUROPA TOOL
MASTERMILL VX
 HIGH PERFORMANCE MULTI-MATERIAL MILLING



EUROPA TOOL **Clarkson** **Osborn**

STANDARD LINE

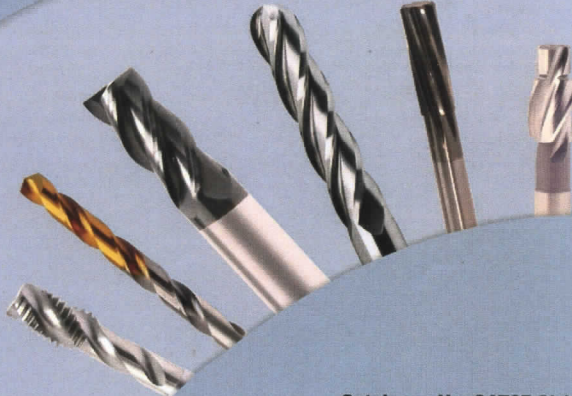

Catalogue No. CAT27 SL19/1

Clarkson EUROPA TOOL
MASTERMILL VX

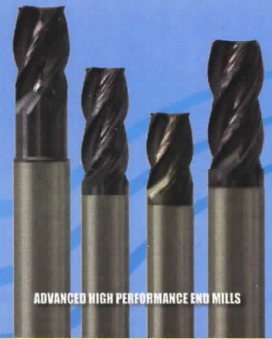

ADVANCED HIGH PERFORMANCE END MILLS

Clarkson EUROPA TOOL
UNIMASTER IDX
 MULTI-MATERIAL INDEXABLE INSERTS



Clarkson EUROPA TOOL
MASTERMILL IDX



INDEXABLE INSERT MILLING TOOLS

Clarkson EUROPA TOOL

DRILLING

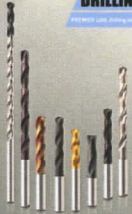

Clarkson EUROPA TOOL

UNIMASTER 002



Clarkson EUROPA TOOL

UNIMASTER



Clarkson EUROPA TOOL

THREADING



Clarkson EUROPA TOOL

MASTERMILL 03200

High Performance profile milling



Copy milling and high feed milling in materials up to 65HRC.

Clarkson

MILLING

PREMIER LINE milling tools.



EUROPA TOOL

Clarkson EUROPA TOOL

PULSAR BLUE

High performance hardened steel milling



Clarkson EUROPA TOOL

UNIMASTER 6300R

High Performance profile milling



Clarkson EUROPA TOOL

ALU-XP

Water polished tools for non-ferrous milling

